

VERMEIREN

Eclips X4 kids 90°

INSTRUCTION MANUAL





Instructions to the specialist dealer

This instruction manual is part and parcel of the product and must accompany every product sold.

Version: B, 2014-08

All rights reserved, including translation.

No part of this manual may be reproduced in any form what so ever (print, photocopy, microfilm or any other process) without written permission of the publisher, or processed, duplicated or distributed by using electronic systems.

© N.V. Vermeiren N.V. 2014

Contents

Preface	2
1 Product description	3
1.1 Intended Use.....	3
1.2 Technical specifications	4
1.3 Components.....	5
1.4 Accessories.....	5
1.5 Location identification plate.....	5
1.6 Explanation of symbols	6
1.7 Safety rules	6
2 Use	7
2.1 Carrying the wheelchair	7
2.2 Mounting the rear wheels (if quick release axle is available).....	7
2.3 Unfolding the wheelchair	7
2.4 Mounting or removing of the footrests	7
2.5 Operating the brakes.....	8
2.6 Transfer in and out the wheelchair	8
2.7 Correct position in the wheelchair	8
2.8 Riding the wheelchair.....	9
2.9 Moving on slopes	9
2.10 Negotiating steps or curbs	9
2.11 Fold up the wheelchair	11
2.12 Taking off the wheels	11
2.13 Backrest adjusting	11
2.14 Transport in the car.....	12
3 Installation and adjustment	12
3.1 Tools	12
3.2 Manner of delivery	12
3.3 Adjusting the seat height and seat angle	13
3.4 Anatomical seat.....	15
3.5 Adjusting seat depth.....	15
3.6 Anatomical backrest.....	16
3.7 Adjust the brakes.....	16
3.8 Adjusting of the footrests	17
3.9 Adjusting of the armrests	17
3.10 Adjusting of the handgrips	18
3.11 Adjusting of the tip cap	18
3.12 Adjusting the stability and the maneuverability.....	19
4 Maintenance	19

Preface

First of all we want to thank you for putting your trust in us by selecting one of our wheelchairs.

The Vermeiren wheelchairs are the result of many years of research and experience. During the development, special attention was given to the ease of use and the serviceability of the wheelchair.

The expected lifetime of your wheelchair is strongly influenced by the care and maintenance of the wheelchair.

This manual will help you get acquainted with the operation of your wheelchair.

Following the user instructions and the maintenance instructions are an essential part of the warranty.

This manual reflects the latest product developments. Vermeiren has the right to introduce changes without the obligation to adapt or replace previously delivered models.

For any further questions, please consult your specialist dealer.

1 Product description

1.1 *Intended Use*

The wheelchair is intended for people with walking difficulties or no walking abilities.

The wheelchair is designed to transport 1 person.

The wheelchair is suited for indoor and outdoor use.

The user can propel the wheelchair by himself or have the wheelchair pushed by an attendant.

The different types of fittings and accessories, and the modular construction allow full use by persons disabled by:

- paralysis
- loss of limbs (leg amputation)
- limb defects or deformations
- stiff or damaged joints
- heart insufficiencies and poor blood circulation
- balance disturbances
- cachexia (decrease in muscle)
- and also for aged persons.

When providing for individual requirements:

- body size and weight (max. 80 kg)
- physical and psychological condition
- residential circumstances
- environment

should be taken into consideration.

Your wheelchair should only be used on surfaces where all four wheels are touching the ground and where there is sufficient contact to propel the wheels equally.

You should practice for use on uneven surfaces (cobblestones, etc.), slopes, curves and to get past obstacles (curbs, etc.).

The wheelchair should not be used as a ladder, nor is it a transport for heavy or hot objects.

When used on mats, carpeted floors or loose floor coverings, the floor covering can get damaged.

Use only Vermeiren approved accessories.

The manufacturer is not liable for damage caused by the lack of or improper service or as a result of not following instructions from this manual.

Compliance with the user and maintenance instructions are an essential part of the guarantee conditions.

1.2 Technical specifications

Technical terms below are valid for the wheelchair in standard settings. If other footrests / armrests or other accessories are used, the tabulated values will change.

Make	Vermeiren	
Address	Vermeirenplein 1/15, B-2920 Kalmthout	
Type	Manual wheelchair	
Model	Eclips X4 90° kids	
Maximum occupant mass	80 kg	
Description	Dimensions	
Effective seat width	320 mm	370 mm
Overall width (depends on the seat width)	500 mm	550 mm
Effective seat depth	310 mm - 370 mm	330 mm - 390 mm
Description	Dimensions Min.	Dimensions Max.
Overall length with footrest	830 mm	1000 mm
Folded length without footrest	630 mm	800 mm
Folded width	310 mm	
Folded height	820 mm	980 mm
Total mass	± 16,00 kg	
Mass of heaviest part	10,40 kg	
Masses of parts that can be dismantled or removed	Footrests: 1,80 kg; Rear wheels: 3,80 kg	
Static stability downhill	7,5° (in standard configuration)	
Static stability uphill	Axle block backwards: 4° Axle block forwards: Anti-tipping device must be standard available	
Static stability sideways	>16° (in standard configuration)	
Obstacle climbing	60 mm	
Seat plane angle	0°	6,5°
Seat surface height at front edge	420 mm	470 mm
Backrest angle	5°	95°
Backrest height	350 mm	400 mm
Distance between footrest and seat	255 mm	365 mm
Angle between seat and footrest	9°	
Angle footplate	14°	
Distance between armpad and seat (With B82 cloth protectors)	150 mm	180 mm
Front location of armrest structure	150 mm	
Handrim diameter	480 mm	
Horizontal location of axle (deflection)	70 mm	120 mm
Minimum turning radius	1530 mm	
Diameter PU Rear wheels	22"	
Tyre pressure, rear (driving) wheels	Max. 3.8 bar	
Diameter PU steering wheels	150 mm	
Tyre pressure, steering wheels	Max. 2.5 bar	
Gas pressure spring	2 x 275 N	
Storage and use temperature	+5 °C	+ 41 °C
Storage and use humidity	30%	70%
We reserve the right to introduce technical changes. Measurement tolerance ± 15 mm / 1,5 kg / °		

Table 1: Technical specifications Eclips X4 kids 90°

The wheelchair complies to the requirements set up in:

ISO 7176-8: Requirements and test methods for static, impact and fatigue strengths.

ISO 7176-16: Resistance to ignition of upholstered parts

1.3 Components

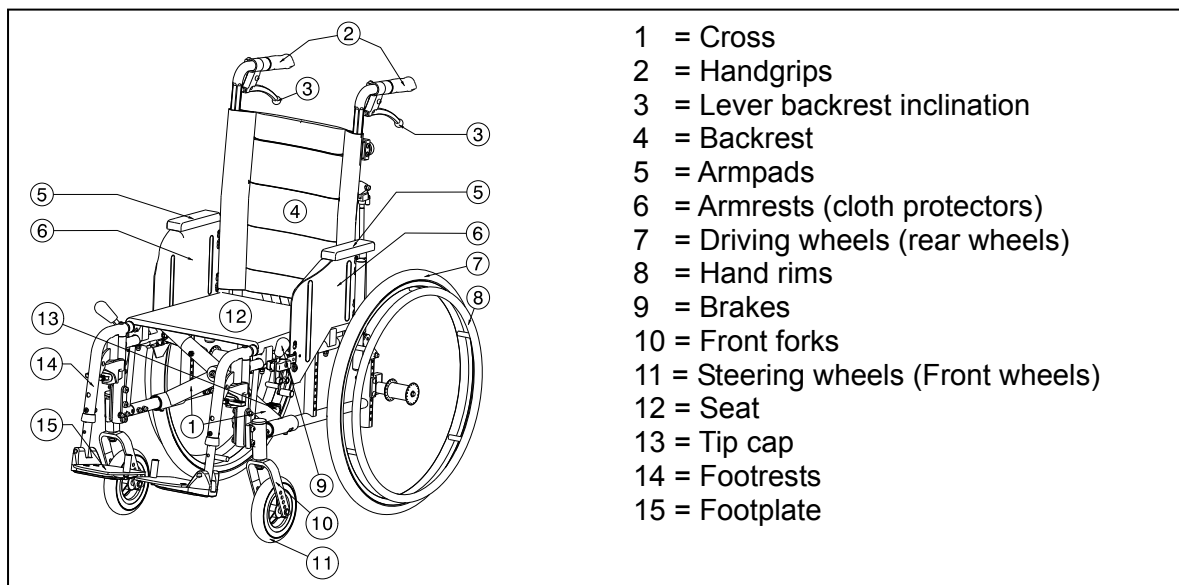

1.4 Accessories

The following accessories are available for the Eclips X4 kids 90°:

- Anterior pelvic belt (B20) for mounting on the tubes of the back
- Anti-tipping device (B78) for mounting on the lower frame
- Armrests (B05)
- Footrests (BK6, BB6)
- Legrests (BZ8)
- Table (B12), Not with cloth protectors B82
- B74 Drum brakes
- T30 Transit wheelchair

Contact your specialist dealer about other accessories. He will gladly advise you.

1.5 Location identification plate

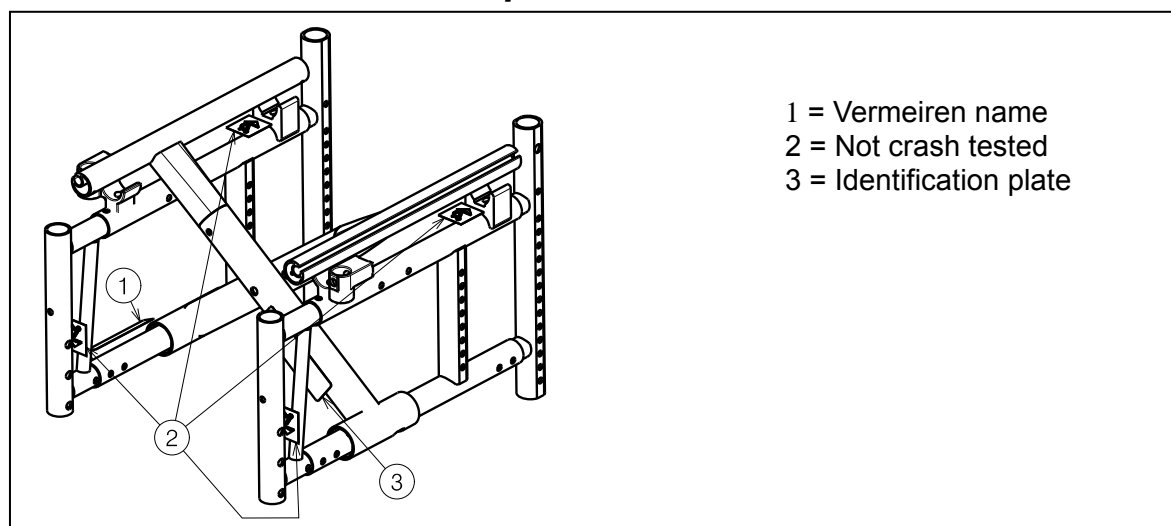

1.6 Explanation of symbols



Maximum mass



Indoor and outdoor use



Maximum Safe Slope



CE conformity



Type designation



Not crash tested

1.7 Safety rules

- ⚠ To prevent injury and/or damage to your wheelchair, make sure that no objects and/or body parts are caught in the spokes of the driving wheels.
- ⚠ The parking brakes should be applied before getting into and out of the wheelchair.
- ⚠ When getting into and out of the wheelchair, do not stand on the footplates. These should be folded up beforehand, or the footrests should be swung completely outwards out of the way.
- ⚠ Investigate the effects of shifting the centre of gravity on the behavior of the wheelchair, for example on up or down gradients, on laterally sloping ground, or when overcoming obstacles. Obtain support from an attendant.
- ⚠ If you want to pick up something (lying in front of, on the side, or to the rear of the wheelchair), you should not lean too far out to avoid tipping over.
- ⚠ When moving through doors, arches, etc. ensure that there is enough room at the sides so that you do not get your hands or arms caught or crushed and that there is no damage to the wheelchair.
- ⚠ Only use your wheelchair according to regulations. For example, avoid uncontrolled rolling against obstacles (steps, curbs, doorframes, etc) or dropping down from ledges. The manufacturer cannot assume liability for damage caused by overloading, collision or other improper use.
- ⚠ Stairs may only be negotiated when aided by another person. If furnishings like drive-on, ramps or lifts are available, use them.
- ⚠ When moving on the public highway, you are subject to the rules of the road.
- ⚠ When driving your wheelchair, you should not be under the influence of alcohol or medicine as in the case of driving other vehicles. This also applies to indoor driving.
- ⚠ When travelling outdoors, adapt your driving to weather and traffic conditions.
- ⚠ When transporting the wheelchair, never pick it up by grasping movable parts (armrests, footrests, etc.)
- ⚠ To be better visible when driving in the dark, wear the brightest possible clothing or clothes with reflectors, and check that the reflectors mounted on the sides and rear of the wheelchair are clearly visible.
- ⚠ Never exceed the maximum load of your wheelchair.
- ⚠ Never use your electric wheelchair as a seat in an automobile or other vehicle.

2 Use

This chapter describes the everyday use. **These instructions are for the user and the specialist dealer.**

The wheelchair is delivered fully assembled by your specialist dealer. The instructions intended for the specialist dealer on how to set up the wheelchair are given in § 3.

2.1 Carrying the wheelchair

The best way to carry the wheelchair is to make use of the wheels and roll the wheelchair.

If this is not possible (e.g. when the rear wheels are taken off for transportation in a car), firmly grasp the frame on the front and the grips. Do not use the foot, armrests or the wheels to grasp the wheelchair.

2.2 Mounting the rear wheels (if quick release axle is available)

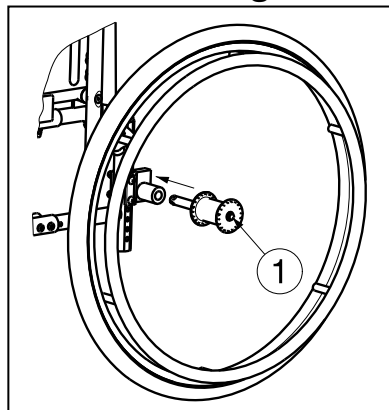

1. Take the rear wheel and push on button ①.
2. Keep the button pushed in and mount the rear wheels axle till it stops.
3. Release the button.
4. Check that the wheel is secured.

2.3 Unfolding the wheelchair

⚠ CAUTION: Risk of clamping – Keep fingers away from moving parts of the wheelchair.

1. Position yourself behind the wheelchair.
2. Use the handgrips to open the wheelchair as much as possible.
3. Position yourself at the front of the wheelchair.
4. Push both seating tubes down till they are fixed in their position.
5. When the push bar is available mount the push bar to the right handgrip.

2.4 Mounting or removing of the footrests

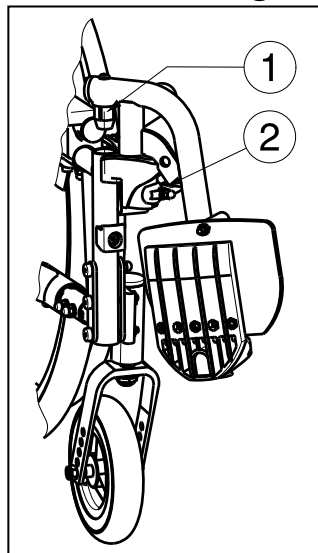

The mounting of the footrests is done as follows:

1. Hold the footrest sideways at the outside of the wheelchair frame and mount the tube hood ① into the frame.
2. Swing the footrest inwards till it clicks in position.
3. Swing the footplate downwards.

To take off the footrests:

1. Pull lever ②.
2. Swing the footrest to the outside of the wheelchair till it comes loose from the guidance.
3. Pull the footrest tube hood ① out the wheelchair frame.

2.5 Operating the brakes

- ⚠ **WARNING:** The brakes are not used to slow down the wheelchair during movements – Use the brake only to prevent the wheelchair from unintended movements.
- ⚠ **WARNING:** Good operation of the brakes is influenced by wear and contamination of the tires (water, oil, mud, ...) – Check the condition of the tires before each use.
- ⚠ **WARNING:** The brakes are adjustable and can wear – Check the operation of the brakes before each use.

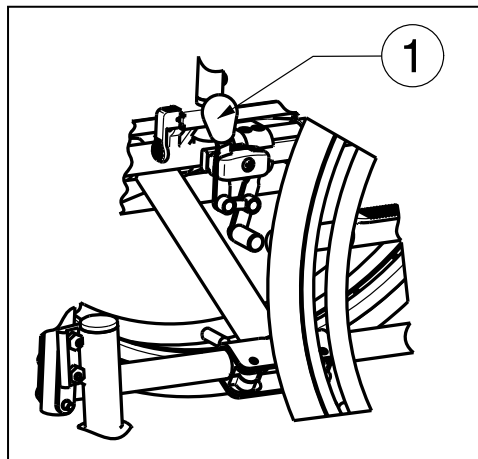

To apply the brakes:

1. Push the brake levers ① forward till you feel a distinctive click.

⚠ **CAUTION:** Risk of unintended movement – Make sure the wheelchair is on a flat horizontal surface before releasing the brakes. Never release both brakes simultaneously.

To release the brakes:

1. Release one brake by pulling the lever ① backwards.
2. Hold the hand-rim of the released wheel with your hand.
3. Release the second brake by pulling the lever backwards.

2.6 Transfer in and out the wheelchair

- ⚠ **CAUTION:** In case you cannot perform the transfer in a safe manner, ask someone to assist you.
- ⚠ **CAUTION:** Risk of tipping over of the wheelchair – Do not stand on the footplates.

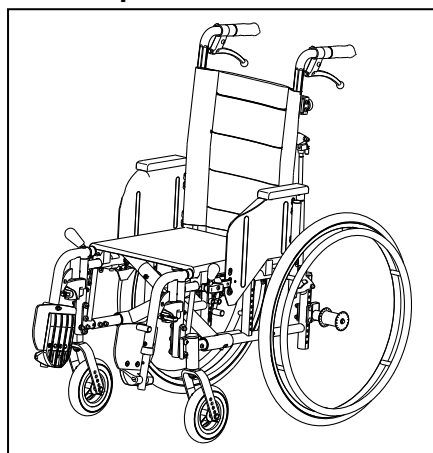

1. Position the wheelchair as close as possible to the chair, couch or bed to/from you wish to transfer.
2. Check both brakes from the wheelchair are in the on position.
3. Fold the footplates upwards to prevent standing on them.
4. If the transfer is on the side of the wheelchair, fold the armrest on that side upwards (if possible: not for B82 armrests) or an attendant can lift the child out the wheelchair.
5. Transfer to/from the wheelchair.

2.7 Correct position in the wheelchair

Some recommendations for a comfortable use of the wheelchair:

- Position your backside as close as possible to the backrest.
- Make sure your upper legs are horizontal – If needed adjust the length of the footrests (see § 3.8.1).

2.8 Riding the wheelchair

- ⚠ **WARNING:** Risk of clamping – Prevent your fingers from being caught by the wheels spokes.
 - ⚠ **WARNING:** Risk of clamping – Be careful passing through restricted passages (e.g. doors).
 - ⚠ **WARNING:** Risk of burns – Be careful when driving in hot or cold environments (sunshine, extreme cold, saunas, etc.) for a sufficient amount of time and when touching - Surfaces can assume the environment temperatures.
1. Release the brakes.
 2. Take both hand rims at their highest position.
 3. Lean forward and push the hand rims forward until straight arms.
 4. Swing your arms loosely back to the hand rims topside and repeat the movement.

2.9 Moving on slopes

- ⚠ **WARNING:** Control your speed – Moving on slopes as slow as possible.
- ⚠ **WARNING:** Consider the capacities of your attendant – If your attendant does not have enough force to control the wheelchair, put on the brakes.
- ⚠ **WARNING:** Risk of tipping over – Lean forward to move your centre of gravity forward. To improve a better stability.



1. If available on the wheelchair, wear the safety belt.
2. Do not attempt moving on too high slopes. The maximum slope angles (upwards and downwards) are mentioned in table 1.
3. Ask an attendant to help you moving on the slope.
4. Lean forward to move your centre of gravity forward.

2.10 Negotiating steps or curbs

2.10.1 Getting down steps or curbs

Riding down low curbs can be done moving forwards. Make sure that the footplates do not touch the ground.



A practiced user can negotiate small steps or curbs by himself:

- ⚠ **WARNING:** Risk of tipping over – If you do not have enough experience with your wheelchair, ask assistance of an attendant.
1. Bring balance on the rear wheels to reduce the pressure on the front wheels.
 2. Negotiate the curbs.

Higher curbs can be taken forward with an attendant:

1. Ask the attendant to tip the wheelchair slightly backwards.
2. Get past the curbs while moving on the rear wheels.
3. Put the wheelchair back on the four wheels.



An experienced user can negotiate higher curbs by himself. This is best done backwards.

1. Turn the wheelchair to have the rear wheels facing the curb.
2. Lean forward to move your centre of gravity forward.
3. Move the wheelchair close to the curbs.
4. Use the hand rim to roll-off wheelchair from the curb in a controlled manner.

2.10.2 Moving up steps or curbs

Moving up steps or curbs with attendant as follows:



1. Prevent the footplates from touching the curb.
2. Ask the attendant to tip the wheelchair backwards, just enough to move the front wheels over the curb.
3. Lean backwards to move your centre of gravity above the rear wheel.
4. Place the front wheels on the curb.
5. Roll rear wheels of the wheelchair over the curb.

Higher curbs are negotiated backwards:

1. Turn the wheelchair to have the rear wheels facing the curb.
2. Lean backwards and move your centre of gravity above the rear wheels.
3. Ask the attendant to pull the wheelchair on the curb.
4. Take back the normal position in the wheelchair.

An experienced user can negotiate curbs by himself:

⚠ WARNING: Risk of tipping over – If you have not enough experience to control the wheelchair, get help from an attendant.



1. Drive until the curbs.
2. Ensure that the footrest do not touch the curbs.
3. Lean backwards so you are balancing on the rear wheels.



4. Role the front wheels balancing over the curbs.
5. Bend forward for more stability.
6. Role the rear wheels over the curbs.

2.10.3 Taking of stairs

Taking of stairs while you staying in the wheelchair shall be according following rules:

⚠ WARNING: Risk of tipping over – Taking of stairs shall always with 2 attendants.

1. Remove the footrests.
2. One attendant tip the wheelchair slightly backwards.
3. The second attendant take the front of the frame.
4. Stay calm, avoid sudden movements and keep your arms inside the wheelchair.
5. Take the steps on the rear wheels of the wheelchair.
6. Mounting the footrests back after taking the stair.

2.11 Fold up the wheelchair

⚠ CAUTION: Chance of pinching – Do not place fingers between the components of the wheelchair.

1. When the push bar is available remove the push bar.
2. Fold or remove the footplates (see § 2.4).
3. Take the seat on the front side and backside and pull it up.
4. Push on the handgrips to fold up the wheelchair further.

2.12 Taking off the wheels

To facilitate the transport off the wheelchair the rear wheels can be taken off:

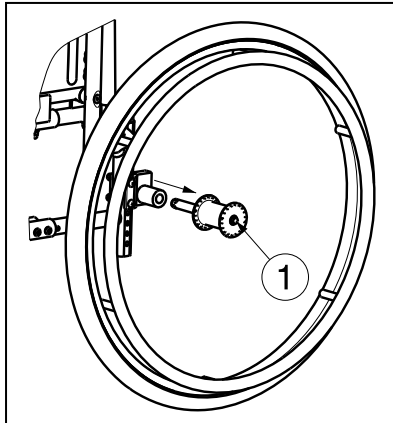

1. Make sure the brakes standing in the off position.
2. Take the wheelchair to the side frame where you want to remove the wheel.
3. Press the button ① in the center of the wheel hub.
4. Pull the wheel away from the frame.

2.13 Backrest adjusting

⚠ WARNING: Risk of tipping over – Be aware that the stability decrease when adjusting the backrest backwards.

⚠ WARNING: Risk of injury – Tighten the parking brakes before adjusting the backrest inclination.

With the model Eclips X4 kids 90° it is possible to set the backrest backwards with a maximum inclination of 90°. Be sure that the patient sits in the chair when the attendant shall perform the backrest adjusting and that the wheelchair does not tip over.

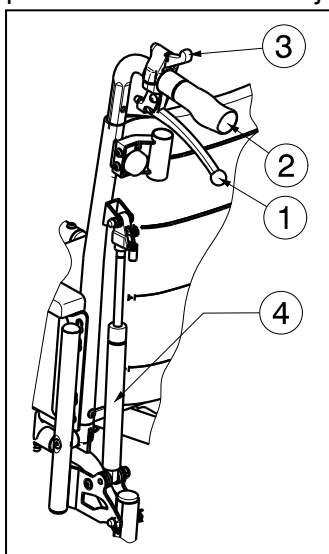

1. Pull lever ① on both sides towards the handgrip ② to adjust the backrest.
2. Pull both back tubes backwards continuously to a maximum inclination of 90°.
3. The gas pressure spring ④ shall be pressed in.

To set the backrest to a vertical position, proceed in the same manner.

If your wheelchair features drum brakes, the levers ① are used as brakes; additional levers ③ have been mounted for backrest adjusting.

2.14 Transport in the car

- ⚠ **DANGER:** Risk of injury – The wheelchair is not suited for use as a seat in a motor vehicle.
- ⚠ **WARNING:** Risk of injury – See that the wheelchair is attached properly. So you can avoid injury from the passengers during collision or sudden braking.
- ⚠ **WARNING:** Risk of injury – Use for attaching the wheelchair and passenger **NEVER** the same seatbelt.

Never use your wheelchair as a seat in an automobile or other vehicle. The wheelchair shall be marked with following symbol.



To transport the wheelchair in the car use following steps:

1. Remove footrests and accessories.
2. Store footrests and accessories safely.
3. If possible, fold the wheelchair and remove the wheels.
4. Place the wheelchair in the luggage place.
5. If the wheelchair and the passenger compartment is NOT separated, attach the frame of the wheelchair securely to the vehicle. You can use the available safety belts in the vehicle.

3 Installation and adjustment

The instructions in this chapter are for the specialist dealer.

The Vermeiren Lightweight wheelchairs Eclips X4 kids 90° has been designed entirely for your comfort. This wheelchair can be adjusted to individual requirements as explained below.

To find a service facility or specialist dealer near you, contact the nearest Vermeiren facility. A list of Vermeiren facilities can be found on the last page.

- ⚠ **WARNING:** Risk of unsafe settings - Use only the settings described in this manual.
- ⚠ **WARNING:** Variation of allowed adjustments can still change the stability of your wheelchair (tilt back or sideways).

3.1 Tools

To set up the wheelchair the following tools are needed.

- Wrench set n° 10 to n° 19
- Allen key set n° 4 to n° 5
- Screwdriver Phillips head

3.2 Manner of delivery

The Vermeiren Eclips X4 kids 90° shall be delivered with:

- 1 frame with armrests (cloth protectors), rear and front wheels
- Back inclination system 90°
- 1 pair footrests
- Tools
- Manual
- Accessories

3.3 Adjusting the seat height and seat angle

- ⚠ **WARNING:** Risk of injury - Make sure that all screws are properly tightened with the appropriate tool.
- ⚠ **WARNING:** Risk of tipping over - When the driving wheels are adjusted, the position of the wheels are altered.

The Vermeiren Eclips X4 kids 90° is adjustable in different seat heights and different seat angles by changing the wheels position. At each height there is a different setting of the front and rear wheels.

Minimum seat height: 420 mm
Minimum seat angle: 0°

Maximum seat height: 470 mm
Maximum seat angle: 6,5°

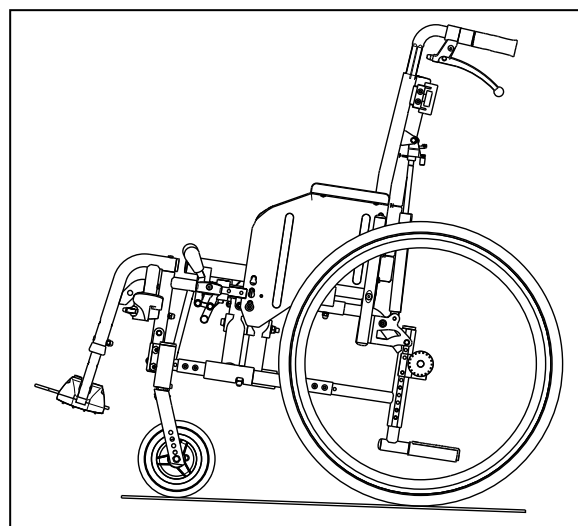
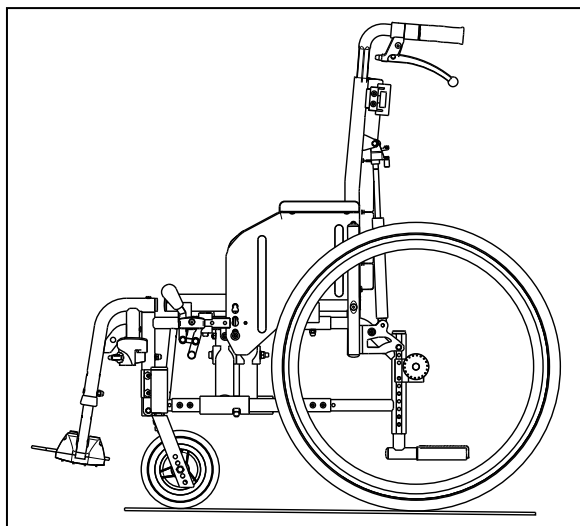

Change the seat height and seat angle according following steps:

* *Front wheel:*

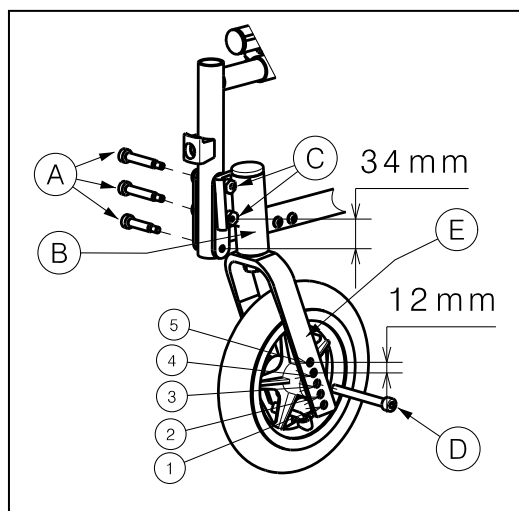

1. Loosen the screws (A) from the steering wheel adapter (B).
 2. Choose correct size for the adapter (B) and fork.
 3. Place the steering wheel adapter in the desired position (2 different positions: steps from 34 mm).
 4. Tighten the screws (A) properly.
- or
5. Loosen the screw (D) from the front fork (E).
 6. Choose the correct position. **Do not use the holes (4) and (5).** (3 different positions: steps from 12 mm).
 7. Tighten the screws (D) properly.

Adjustment of the slope nuts © from the steering wheels.

⚠ WARNING: Risk of injury - Make sure that the eccentric screw settings are identical on both front-wheel adapters and, before using the wheelchair.

This figure illustrates the principle. The position of the screw thread is indicated by a number.

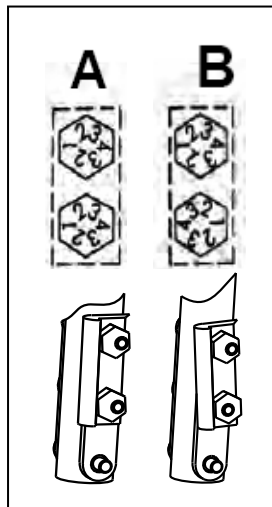

A Shows the frame when the seat is horizontal and the adapter is perpendicular to the ground.

B Shows the frame when the seat is tilted slightly and the adapter is not perpendicular.

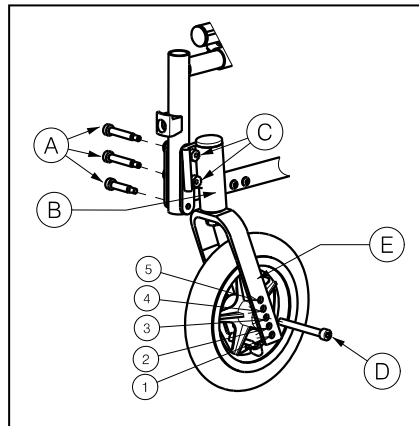

* *Rear wheel:*

1. Remove the rear wheels (see § 2.12).
2. Loosen the fixing screws (A) from the rear axle block (B).
3. Push the axle block (B) upwards or downwards to the desired height (3 different positions: steps from 15 mm).
4. Tighten the screws (A) properly.
5. Mount the rear wheels.
6. Adjust the brakes according § 3.7.

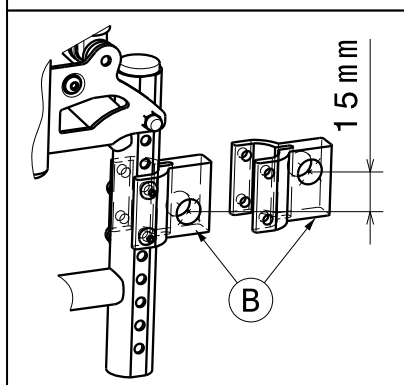
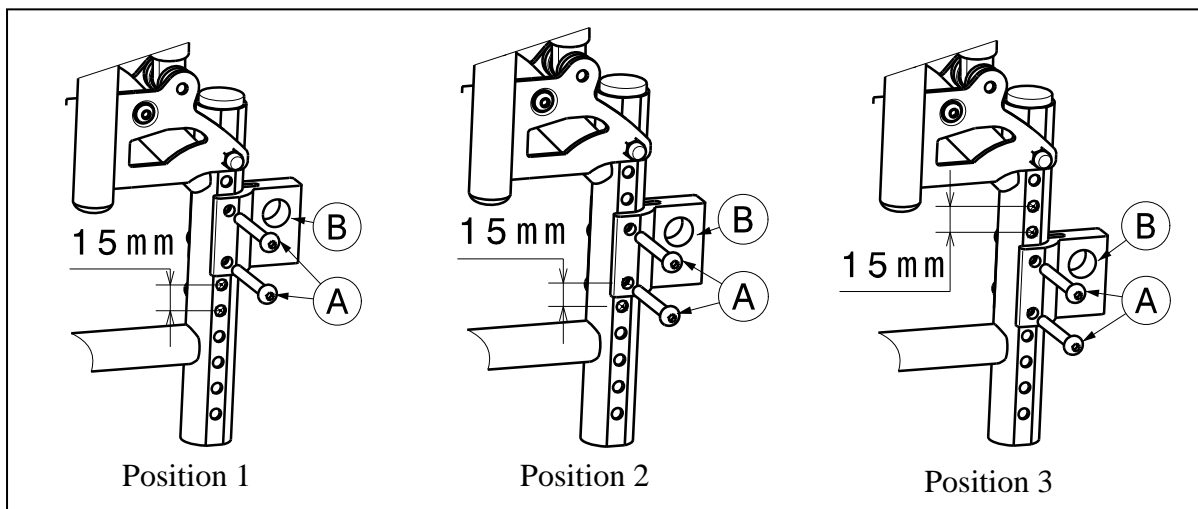

It is also possible to rotate the rear axle block (B) (2 positions: steps from 15 mm).

Some of the wheelchairs Eclips X4 kids Aktief are made with an adjustable axle adjuster. With these adjuster you can also change the seat height.

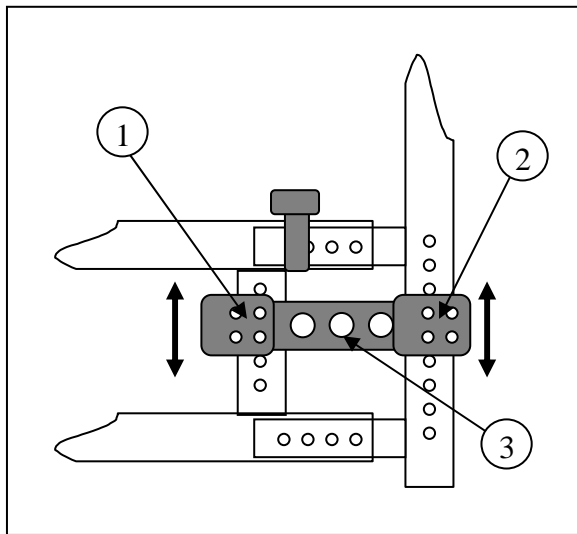

1. Remove the screws ① and ②.
2. Push/Pull the adjustable axle adjuster ③ upwards or downwards to the required height.
3. Retighten the screws ① and ②.

3.4 Anatomical seat

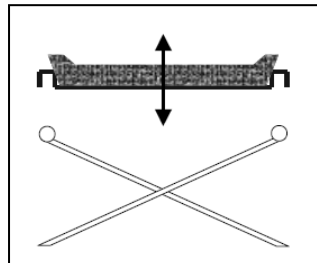

If you have opted for an anatomical padded seat, place it on the tubular cross-hinge so that the seat's supports engage equally with the cross-hinge. In the wooden base you will find slots that are placed in the hinge's cross-pieces. To fold up the wheelchair, remove the seat by pulling it upwards.

3.5 Adjusting seat depth

⚠ WARNING: Risk of injury - Make sure that all screws are properly tightened before using the wheelchair.

The seat depth can be adjusted from 310 mm to 370 mm in steps from 20 mm for seat width 320 mm and from 330 mm to 390 mm in steps from 20 mm for seat width 370 mm.

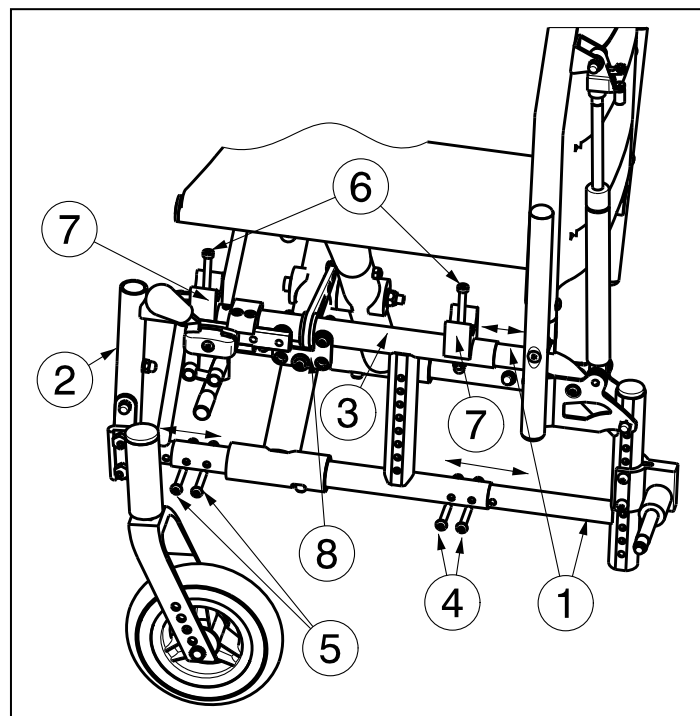

Adjust the seat depth according following procedure:

1. Remove the armrests, footrests and rear wheels.
2. Loosen the screws ④.
3. Loosen the screws ⑤.
4. Remove the crosses from the seat located on the main frame ③ by folding the wheelchair.
5. Remove the screws ⑥ located in the blocks for the cross ⑦ on the main frame ③.

6. Remove the adjustable axle adapter, if available on your wheelchair.
7. Adjust the seat depth to the desired position by moving the backframe ① and/or seat frame ② steps from 20 mm.
8. Tighten all the screws properly by hand.
9. Fold the flap of the backrest under the seat (Velcro fastening), to close the gap between the back frame and the seat.
10. Adjusting the seat is not necessary.
11. Replace the armrests, footrests and rear wheels. Mount the armrests in the correct hole of attachment plate ③.

3.6 Anatomical backrest

- ⚠ **WARNING:** Risk of injury – Check that the backrest is secure before use.
- ⚠ **WARNING:** Risk of injury – Avoid getting your fingers caught during the assembly process.

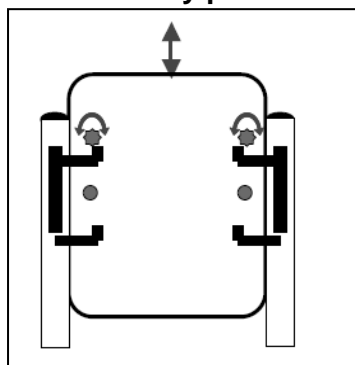

To use the anatomical backrest, proceed as follows:

1. Unscrew the flexible backrest.
2. Loosely screw on the brackets for the backrest.
3. Insert the backrest into the brackets from above.
4. Tighten the screws holding the brackets for the backrest.
5. Insert and tighten the safety screws for the backrest.
6. Add the armrests.

3.7 Adjust the brakes

- ⚠ **WARNING:** Risk of injury – Brakes may only be adjusted by your specialist dealer.

Adjust the brakes according following rules:

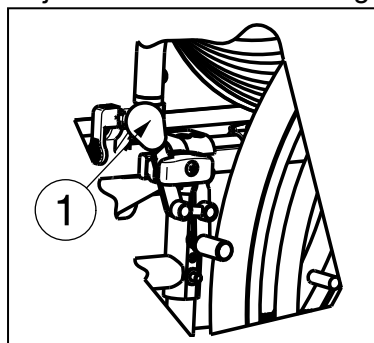

1. Install the wheels according § 2.2.
2. Disconnect the brakes by pulling lever ① backwards.

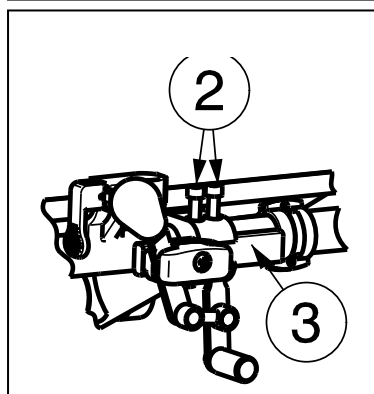

3. Loosen the bolts ② so the brake mechanism can slide over the guide ③.
4. Pull the brake mechanism over the guide ③ to the desired position.
5. Retighten the bolts ②.
6. Check working of the brakes.
7. If necessary repeat the above steps until the brakes are adjusted well.

3.8 Adjusting of the footrests

3.8.1 Length of the footrests

⚠ CAUTION: Risk of damage – Avoid that the footrests make any contact with the ground. Keep a minimum distance from 60 mm above the ground.

Adjust the length of the footrests as follow (2 positions possible: steps 35 mm → holes outside tube, 4 positions possible: steps 25 mm → inner tube): (Fig A)

1. Remove the screw ①.
2. Adjust the length of the footrest to a comfortable length.
3. Tighten the screw ① properly.

3.8.2 Depth of the footplate

Adjust the depth of the footplate as follow (in three different positions: steps 20 mm):

1. Remove the screws ① (Fig B).
2. Adjust the depth of the footrest to a comfortable position (Fig A).
Position 1: hole 2 and 4
Position 2: hole 3 and 5
Position 3: hole 4 and 6
3. Tighten the screws properly ① (Fig B).

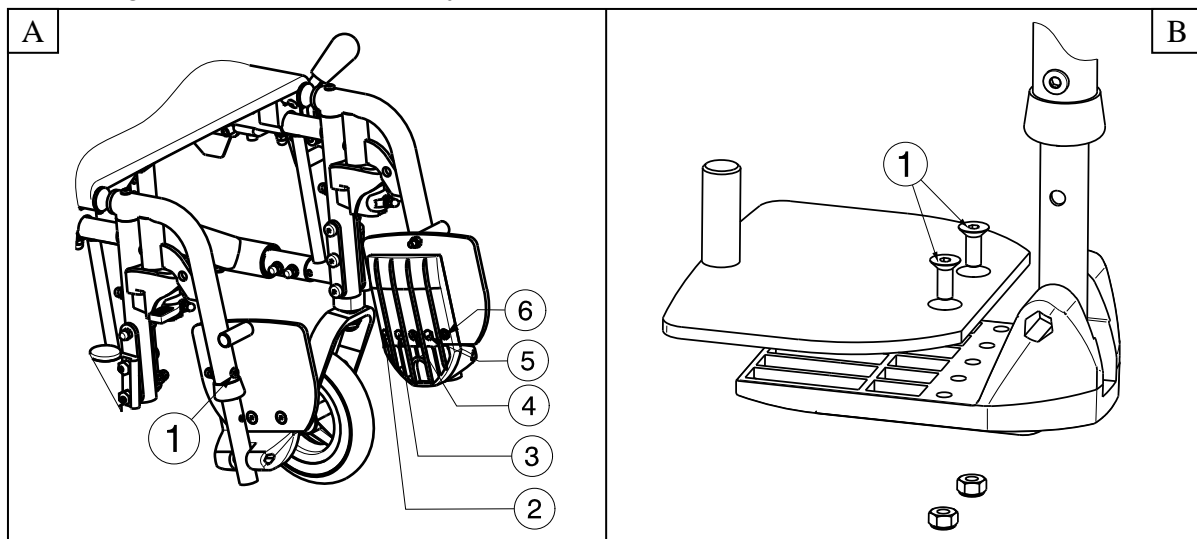

3.9 Adjusting of the armrests

⚠ CAUTION: Risk of clamping – Do not place fingers, buckles and clothes between the splash guards and rear wheels.

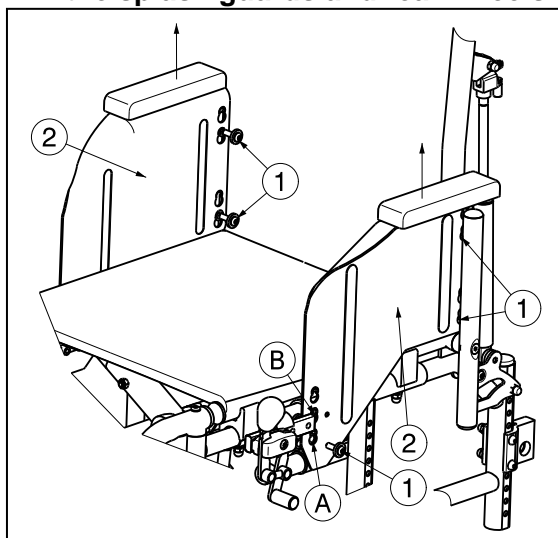

The armrests of the wheelchair can be adjusted in 2 different positions.

Height of armpad	Holes
150 mm	A
180 mm	B

Table 2: Height of armpad

1. Remove the screws ①.
2. Grasp the armrest ② on the top.
3. Remove the armrest ②.
4. Adjust the armrest ② in the desired position.
5. Mount the armrest ②.
6. Tighten the screws ① properly.
7. Check that the armrest ② is firmly fixated.

3.10 Adjusting of the handgrips

- ⚠ **WARNING:** Risk of injury - Make sure that all screws are properly tightened with the appropriate tool.
- ⚠ **WARNING:** Risk of tipping over - Make sure that the tubes of the handgrips are positioned identically on both sides.

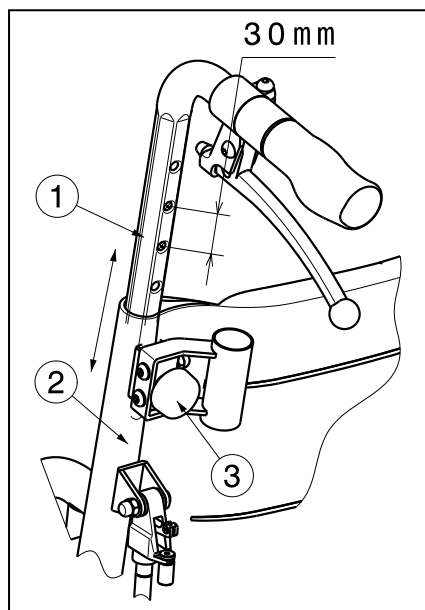

With the model Eclips X4 kids 90° you can adjust the height of the handgrips ① in back tube ②.

1. Loosen the star knob ③.
2. Set the handgrips to the required height (6 different positions: steps of 30 mm.)
3. Retighten the star knob ③ again.

The back cushion is not adjustable in different heights. The back height (BH: 300 mm, 350 mm, 400 mm) must be indicated when ordered.

3.11 Adjusting of the tip cap

- ⚠ **WARNING:** Risk of injury - Make sure that all screws are properly tightened with the appropriate tool.

A tip cap is mounted on the lower back frame that can be adjusted in its height depending on the seat height of the wheelchair.

The tip cap can be placed in 2 different position with a difference of 15 mm.

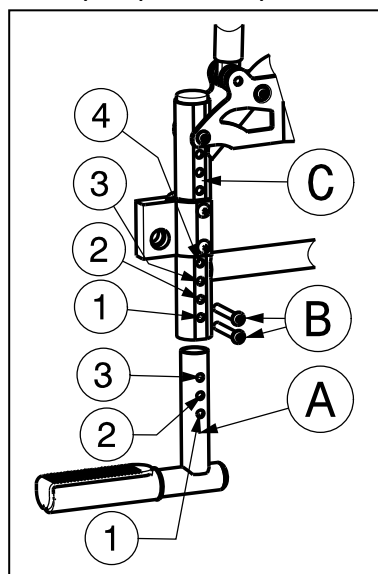

1. Remove the screws ②.
2. Adjust the height of the tip cap to a comfortable position.

Tip cap height	Tube tip cap ④	Tube frame ③
115 mm (Standard)	Hole 1 and 3	Hole 1 and 3
130 mm	Hole 1 and 3	Hole 2 and 4

Table 3: Tip cap heights for wheelchair with seat height of 420 mm

3. Tighten the screws properly ②. (Fig C)

If an anti-tipping is installed, it replaces the addition of the tip cap and can be used accordingly.

3.12 Adjusting the stability and the maneuverability

- ⚠ **WARNING:** Risk of injury - Make sure that all screws are properly tightened with the appropriate tool.
- ⚠ **WARNING:** Risk of injury - Make sure that the axle adapters ① of the rear wheels on both sides are mounted in the same position.
- ⚠ **WARNING:** Risk of tipping over - Be aware that you change the stability of the wheelchair.

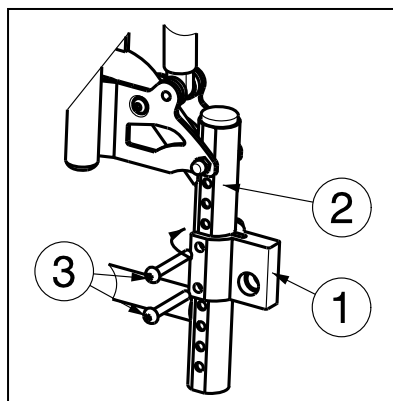

The driving wheels are mounted in an axle adapter ① at the bottom of the back frame ②.

1. Loosen the fixing screws ③.
2. Turn the axle adapter ① to the front or back until the desired position.
3. Tighten the screws properly ③.
4. Adjust the brakes.

Standard shall be an anti-tipping device mounted on the wheelchair when the axle adapter ① is positioned to the front.

Some of the wheelchairs are made with an adjustable axle adjuster. With these adjuster you can also change the stability and the manoeuvrability of your wheelchair.

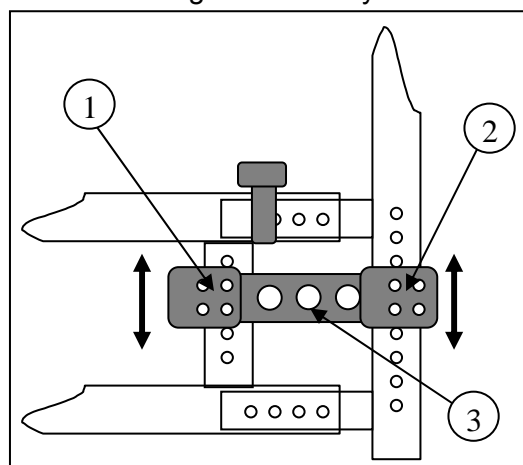

1. Remove the screws ① and ②.
2. Push/Pull the adjustable axle adjuster ③ upwards or downwards to the required height or mount the rear wheel in another axle mounting ③.
3. Retighten the screws ① and ②.
4. Adjust the brakes.

Please note that your wheelchair might become tipping over. To prevent this, you can also mount an anti-tipping device.

4 Maintenance

For the maintenance manual of the manual wheelchairs refer to the Vermeiren website: www.vermeiren.be.



SERVICE

The manual wheelchair was serviced:

Dealer's stamp:

Date:

Dealer's stamp:

Date:

Dealer's stamp:

Date:

Dealer's stamp:

Date:

Dealer's stamp:

Date:

Dealer's stamp:

Date:

Dealer's stamp:

Date:

Dealer's stamp:

Date:

Dealer's stamp:

Date:

Dealer's stamp:

Date:

- For service checklists an additional technical information, please see our specialist dealers nearest to you. More information on our website at: www.vermeiren.com.

Belgium

N.V. Vermeiren N.V.

Vermeirenplein 1 / 15
B-2920 Kalmthout
Tel: +32(0)3 620 20 20
Fax: +32(0)3 666 48 94
website: www.vermeiren.be
e-mail: info@vermeiren.be

France

Vermeiren France S.A.

Z. I., 5, Rue d'Ennevelin
F-59710 Avelin
Tel: +33(0)3 28 55 07 98
Fax: +33(0)3 20 90 28 89
website: www.vermeiren.fr
e-mail: info@vermeiren.fr

Italy

Vermeiren Italia

Viale delle Industrie 5
I-20020 Arese MI
Tel: +39 02 99 77 07
Fax: +39 02 93 58 56 17
website: www.reatime.it
e-mail: info@reatime.it

Poland

Vermeiren Polska Sp. z o.o

ul. Łączna 1
PL-55-100 Trzebnica
Tel: +48(0)71 387 42 00
Fax: +48(0)71 387 05 74
website: www.vermeiren.pl
e-mail: info@vermeiren.pl

Czech Republic

Vermeiren ČR S.R.O.

Nadrazni 132
702 00 Ostrava 1
Tel: +420 596 133 923
Fax: +420 596 133 277
website: www.vermeiren.cz
e-mail: info@vermeiren.cz

Germany

Vermeiren Deutschland GmbH

Wahlerstraße 12 a
D-40472 Düsseldorf
Tel: +49(0)211 94 27 90
Fax: +49(0)211 65 36 00
website: www.vermeiren.de
e-mail: info@vermeiren.de

Austria

L. Vermeiren Ges. mbH

Winetzhammerstraße 10
A-4030 Linz
Tel: +43(0)732 37 13 66
Fax: +43(0)732 37 13 69
website: www.vermeiren.at
e-mail: info@vermeiren.at

Switzerland

Vermeiren Suisse S.A.

Hühnerhubelstraße 59
CH-3123 Belp
Tel: +41(0)31 818 40 95
Fax: +41(0)31 818 40 98
website: www.vermeiren.ch
e-mail: info@vermeiren.ch

Spain / Portugal

Vermeiren Iberica, S.L.

Carratera de Cartellà, Km 0,5
Sant Gregori Parc Industrial Edifici A
17150 Sant Gregori (Girona)
Tel: +34 972 42 84 33
Fax: +34 972 40 50 54
website: www.vermeiren.es
e-mail: info@vermeiren.es