

VERMEIREN

V100 XL

INSTRUCTION MANUAL





Instructions to the specialist dealer

This instruction manual is part and parcel of the product and must accompany every product sold.

Version: A, 2012-02

All rights reserved, including translation.

No part of this manual may be reproduced in any form whatsoever (print, photocopy, microfilm or any other process) without written permission of the publisher, or processed, duplicated or distributed by using electronic systems.

© N.V. Vermeiren N.V. 2012

Contents

Preface	2
1 Productdescription	3
1.1 Intended Use.....	3
1.2 Technical specifications	4
1.3 Drawing	5
1.4 Accessories.....	5
1.5 Location identification plate.....	6
1.6 Explanation of symbols	6
2 Use	6
2.1 Carrying the wheelchair	6
2.2 Mounting the rear wheels.....	7
2.3 Unfolding the wheelchair	7
2.4 Mounting or removing of push bar	7
2.5 Mounting or removing of the footrest.....	8
2.6 Operating the brakes.....	8
2.7 Mounting or removing of arm supports	9
2.8 Transfer in and out the wheelchair	10
2.9 Correct position in the wheelchair	11
2.10 Riding the wheelchair.....	11
2.11 Moving on slopes	11
2.12 Negotiating steps or curbs	11
2.13 Fold up the wheelchair	13
2.14 Taking off the wheels	13
2.15 Transport in the car.....	13
3 Installation and adjustment	14
3.1 Tools	14
3.2 Manner of delivery	14
3.3 Adjusting the seat height	14
3.4 Adjust the brakes	16
3.5 Adjusting of the footrest.....	16
3.6 Adjusting the arm support	17
4 Maintenance	17
4.1 Regular Maintenance.....	17
4.2 Shipping and storage	18
4.3 Care	18
4.4 Inspection	19
4.5 Disinfection	19
5 Guarantee	21
6 Disposal	21
7 Declaration of conformity	21
8 Maintenance plan	22
9 Disinfection book	22



Preface

First of all we want to thank you for putting your trust in us by selecting one of our wheelchairs.

The Vermeiren wheelchairs are the result of many years of research and experience. During the development, special attention was given to the ease of use and the serviceability of the wheelchair.

The expected lifetime of 8 years for your wheelchair is strongly influenced by the care and maintenance of the wheelchair.

This manual will help you get acquainted with the operation of your wheelchair.

Following the user instructions and the maintenance instructions are an essential part of the warranty.

This manual reflects the latest product developments. Vermeiren has the right to introduce changes without the obligation to adapt or replace previously delivered models.

For any further questions, please consult your specialist dealer.

1 Productdescription

1.1 *Intended Use*

The wheelchair is intended for people with walking difficulties or no walking abilities.

The wheelchair is designed to transport 1 person.

The wheelchair is suited for indoor and outdoor use.

The user can propel the wheelchair by himself or have the wheelchair pushed by an attendant.

The different types of fittings and accessories, and the modular construction allow full use by persons disabled by:

- paralysis
- loss of limbs (leg amputation)
- limb defects or deformations
- stiff or damaged joints
- heart insufficiencies and poor blood circulation
- balance disturbances
- cachexia (decrease in muscle)
- and also for aged persons.

When providing for individual requirements:

- body size and weight (max. 170kg)
- physical and psychological condition
- residential circumstances
- environment

should be taken into consideration.

Your wheelchair should only be used on surfaces where all four wheels are touching the ground and where there is sufficient contact to propel the wheels equally.

You should practice for use on uneven surfaces (cobblestones, etc.), slopes, curves and to get past obstacles (curbs, etc.).

The wheelchair should not be used as a ladder, nor is it a transport for heavy or hot objects.

When used on mats, carpeted floors or loose floor coverings, the floor covering can get damaged.

Use only Vermeiren approved accessories.

The manufacturer is not liable for damage caused by the lack of or improper service or as a result of not following instructions from this manual.

Compliance with the user and maintenance instructions are an essential part of the guarantee conditions.

1.2 Technical specifications

Technical terms below are valid for the wheelchair in standard settings.
If other footrest / arm support or other accessories are used, the tabulated values will change.

Make	Vermeiren		
Address	Vermeirenplein 1/15, B-2920 Kalmthout		
Type	Manual wheelchair		
Model	V100 XL		
Maximum occupant mass	170 kg		
Description	Dimensions		
Effective seat width	530 mm	560 mm	600 mm
Overall width (depends on the seat width)	740 mm	770 mm	810 mm
Description	Dimensions Min.	Dimensions Max.	
Overall length with legrest	1060 mm		
Folded length	1060 mm		
Folded width	375 mm		
Folded height	890 mm	950 mm	
Total mass	21,4 kg		
Mass of heaviest part	13,7 kg		
Masses of parts that can be dismantled or removed	Foot supports: 1,75 kg; Arm supports: 1,80 kg; Rear wheels: 4,05 kg		
Static stability downhill	7°		
Static stability uphill	9°		
Static stability sideways	18°		
Obstacle climbing	60 mm		
Seat plane angle	5°		
Effective seat depth	490 mm		
Seat surface height at front edge	470 mm	530 mm	
Backrest angle	5°		
Backrest height	380 mm		
Distance between footrest and seat	450 mm		
Angle between seat and footrest	10°		
Distance between armrest and seat	220 mm	240 mm	
Front location of armrest structure	410 mm		
Handrim diameter	535 mm		
Horizontal location of axle (deflection)	20 mm		
Minimum turning radius	1616 mm		
Diameter Krypton PU Rear wheels	22"	24"	
Tyre pressure, rear (driving) wheels (only for pneumatic tyres)	Max. 3.5 bar		
Diameter Krypton PU steering wheels	200 mm		
Tyre pressure, steering wheels (only for pneumatic tyres)	Max. 2.5 bar		
Storage and use temperature	+ 5 °C	+ 41 °C	
Storage and use humidity	30%	70%	
We reserve the right to introduce technical changes. Measurement tolerance ± 15 mm / 1,5 kg / °			

Table 1: Technical specifications

The wheelchair complies to the requirements set up in:

ISO 7176-8: Requirements and test methods for static, impact and fatigue strengths.

ISO 7176-16: Resistance to ignition of upholstered parts

1.3 Drawing

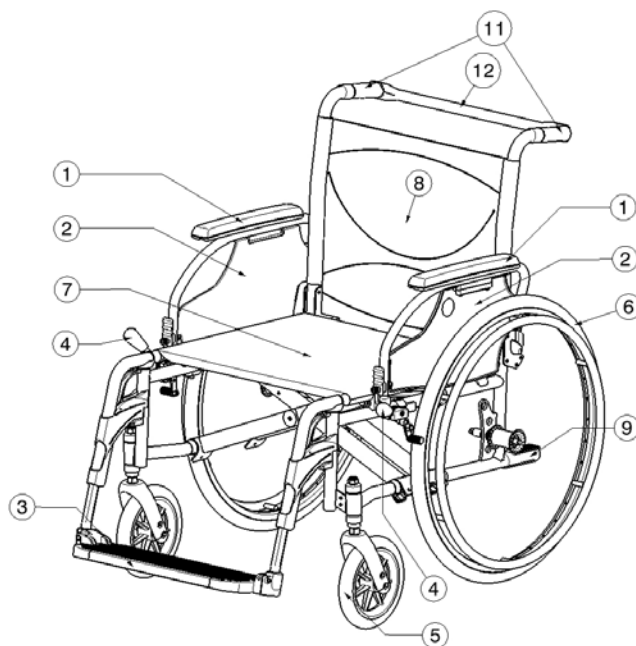
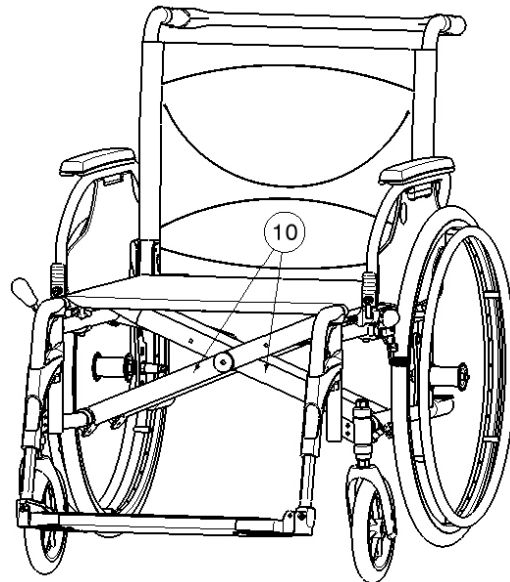

- 1 = Armrests
- 2 = Arm supports
- 3 = Footplate
- 4 = Brakes
- 5 = Steering wheels (front wheels)
- 6 = Driving wheels (rear wheels)
- 7 = Seat
- 8 = Back
- 9 = Tip cap
- 10 = Cross
- 11 = Handles
- 12 = Push bar

1.4 Accessories

The following accessories are available for the V100 XL:

- Anterior pelvic belt (B20) for mounting on the tubes of the back (see according manual)
- Anti-tipping device (B78) for mounting on the bottom frame (see according manual)

1.5 Location identification plate

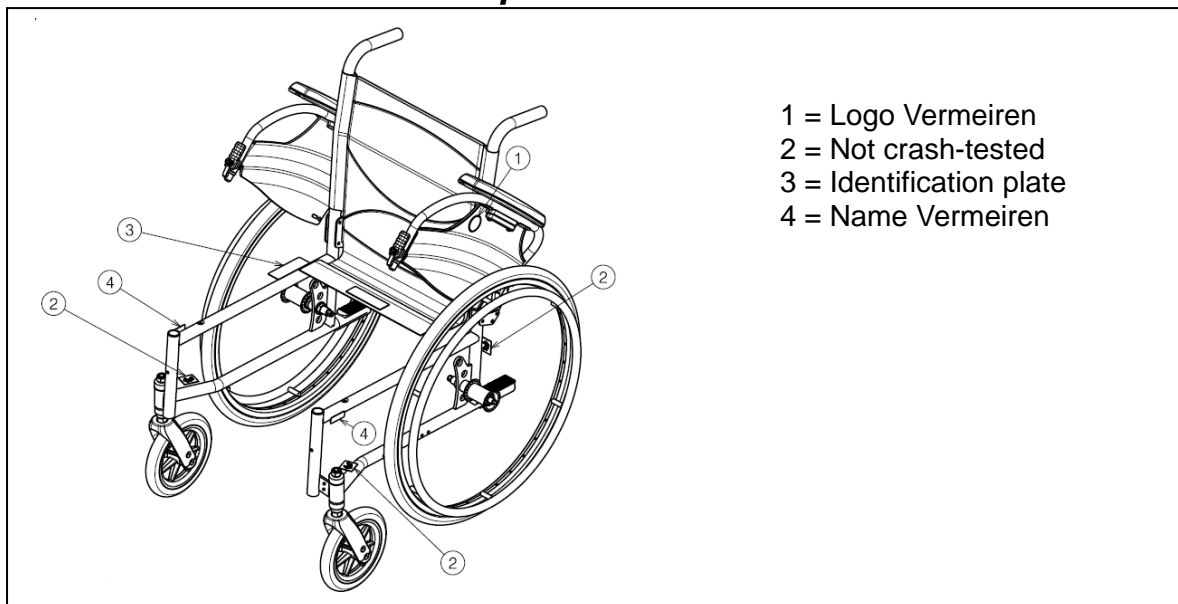

1.6 Explanation of symbols



Maximum mass



Indoor and outdoor use



Down slope



Up slope



CE conformity



Not crash-tested

2 Use

This chapter describes the everyday use. **These instructions are for the user and the specialist dealer.**

The wheelchair is delivered fully assembled by your specialist dealer. The instructions intended for the specialist dealer on how to set up the wheelchair are given in § 3.

2.1 Carrying the wheelchair

The best way to carry the wheelchair is to make use of the wheels and roll the wheelchair.

If this is not possible (e.g. when the rear wheels are taken off for transportation in a car), firmly grasp the frame on the front and the grips. Do not use the foot or arm rests or the wheels to grasp the wheelchair.

2.2 Mounting the rear wheels

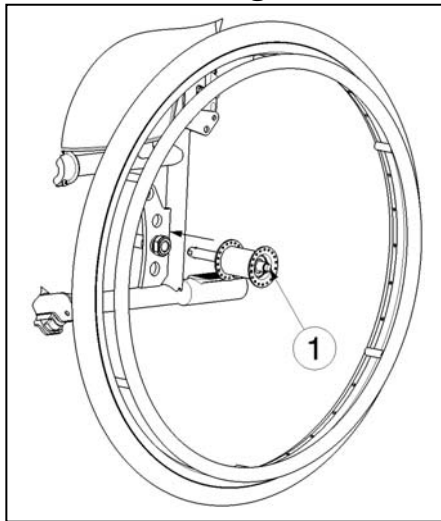

1. Take the rear wheel and push on button ①.
2. Keep the button pushed in and mount the rear wheels axle till it stops.
3. Release the button.
4. Check that the wheels is secured.

2.3 Unfolding the wheelchair

⚠ CAUTION: Risk of clamping – Keep fingers away from moving parts of the wheelchair.

1. Position yourself behind the wheelchair.
2. Use the hand-grips to open the wheelchair as much as possible.
3. Position yourself at the front of the wheelchair.
4. Push both seating tubes down till they are fixed in their position.
5. Mount the push bar to the right hand-grip (standing behind the wheelchair)

2.4 Mounting or removing of push bar

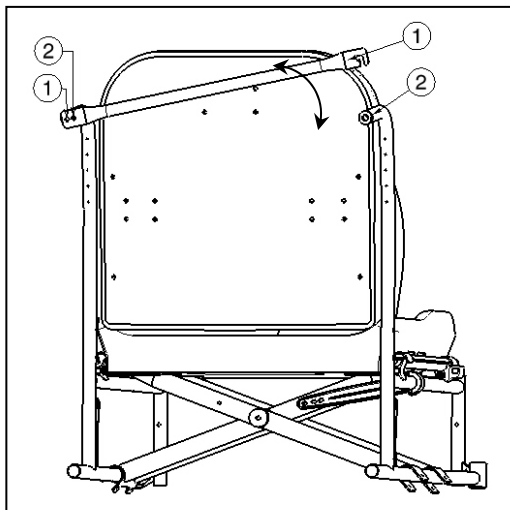

The mounting of the push bar is done as follows:

1. Mount the push bar with the starknob in the left hand-grip.
2. Swing the push bar to the right.
3. Mount clip ① over the right hand-grip ②. When this is difficult it is possible the push bar is too long. Place the push bar on the left-hand-grip with the starknob in hole ②.

To take off the Push bar:

1. Loosen the starknob on the right hand-grip.
2. Remove clip ① from the right hand-grip ②.

2.5 Mounting or removing of the footrest

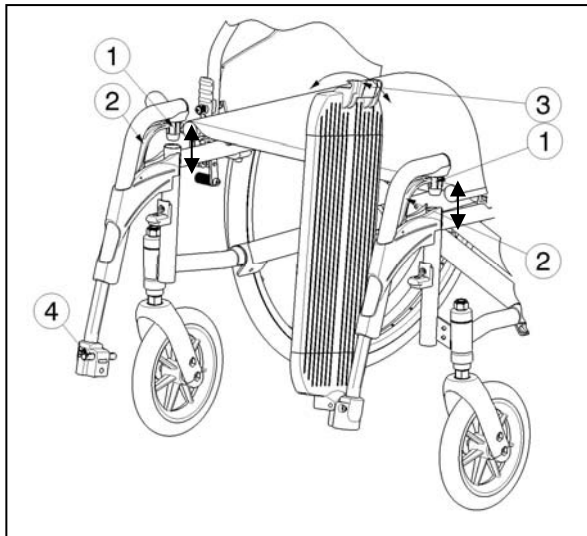

The mounting of the footrest is done as follows:

1. Hold the footrest sideways at the outside of the wheelchairs frame and mount the tube hood ① into the frame.
2. Swing the footrest inwards till it clicks in position.
3. Swing the foot plate downwards until the clip ③ lock over pen ④

To take off the footrests:

1. Make clip ③ loose from pen ④.
2. Swing the footplate upwards.
3. Pull handle ②.
4. Swing the footrest to the outside of the wheelchair till it comes loose from the guidance.
5. Pull the footrest from tube hood ①.

2.6 Operating the brakes

- ⚠ **WARNING:** The brakes are not used to slow down the wheelchair during movements – Use the brake only to prevent the wheelchair from unintended movements.
- ⚠ **WARNING:** Good operation of the brakes is influenced by wear and contamination of the tires (water, oil, mud, ...) – Check the condition of the tires before each use.
- ⚠ **WARNING:** The brakes are adjustable and can wear – Check the operation of the brakes before each use.

To apply the brakes:

1. Push the brake handles forward till you feel a distinctive click.

- ⚠ **CAUTION:** Risk of unintended movement – Make sure the wheelchair is on a flat horizontal surface before releasing the brakes. Never release both brakes simultaneously.

To release the brakes:

1. Release one brake by pulling the handle backwards.
2. Hold the hand-rim of the release wheel with your hand.
3. Release the second brake by pulling the handle backwards.

2.7 Mounting or removing of arm supports

The arm supports of the wheelchair can be mounted by following instructions.

⚠ CAUTION: Risk of clamping – Keep fingers, buckles and clothes away from the bottom side of the arm support.

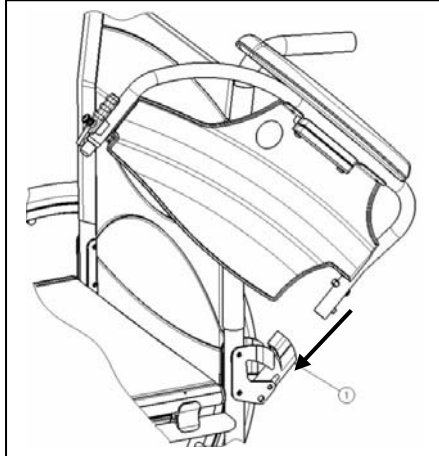

1. Mount the rear tube of the arm rest in tube hood ①.
2. Make sure the arm support clicks in the locking mechanism.
3. Fold the arm rest forward.

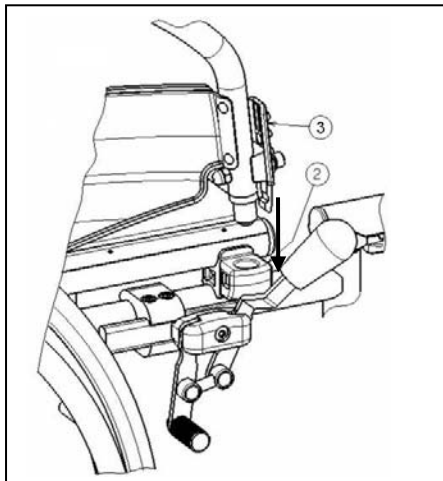

4. Click the front tube of the arm rest in tube hood ②.

To open and remove the arm rest:

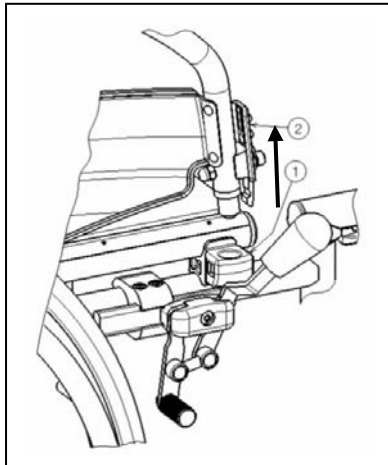

1. Press lever ② and pull the front of the arm rest upwards.
2. Fold the arm rest backwards.

3. To remove the arm rest, press button ③ and pull the rear of the arm support from tube hood ④.

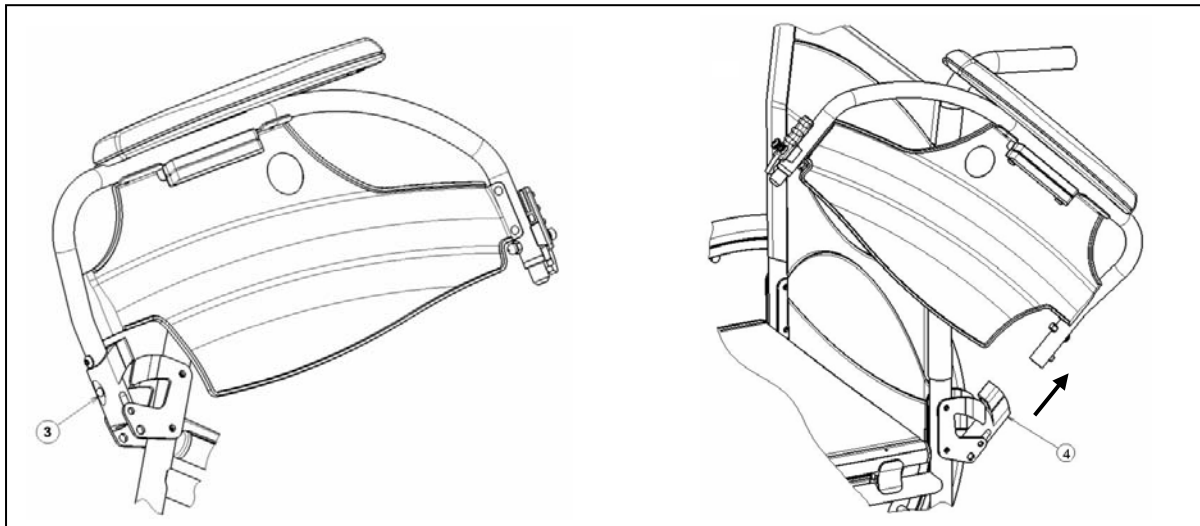

2.8 Transfer in and out the wheelchair

- ⚠ **CAUTION:** In case you cannot perform the transfer in a safe manner, ask someone to assist you.
- ⚠ **CAUTION:** Risk of tipping over of the wheelchair – Do not stand on the foot plate.



1. Position the wheelchair as close as possible to the chair, couch or bed to/from you wish to transfer.
2. Check both brakes from the wheelchair are in the on position.
3. Fold the foot plate upwards to prevent standing on them.
4. If the transfer is on the side of the wheelchair, fold the arm support on that side upwards. (see § 2.7)
5. Transfer to/from the wheelchair.

2.9 Correct position in the wheelchair

Some recommendations for a comfortable use of the wheelchair:

- Position your backside as close as possible to the back rest.
- Make sure your upper legs are horizontal – If needed adjust the length of the foot rests. (see § 3.5)

2.10 Riding the wheelchair

- ⚠ **WARNING: Risk of clamping – Prevent your fingers from being caught by the wheels spokes.**
 - ⚠ **WARNING: Risk of clamping – Be careful passing through restricted passages (e.g. doors).**
 - ⚠ **WARNING: Risk of burns – Be careful when driving in hot or cold environments (sunshine, extreme cold, saunas, etc.) for a sufficient amount of time and when touching - Surfaces can assume the environment temperatures.**
1. Release the brakes.
 2. Take both hand rims at their highest position.
 3. Lean forward and push the hand rims forward until straight arms.
 4. Swing your arms loosely back to the hand rims topside and repeat the movement.

2.11 Moving on slopes

- ⚠ **WARNING: Control your speed – Moving on slopes as slow as possible.**
- ⚠ **WARNING: Consider the capacities of your attendant – If your attendant does not have enough force to control the wheelchair, put on the brakes.**
- ⚠ **WARNING: Risk of tipping over – Lean forward to move your centre of gravity forward. To improve a better stability.**



1. If available on the wheelchair, wear the safety belt.
2. Do not attempt moving on too high slopes. The maximum slope angles (upwards and downwards) are mentioned in table 1.
3. Ask an attendant to help you moving on the slope.
4. Lean forward to move your centre of gravity forward.

2.12 Negotiating steps or curbs

2.12.1 Getting down steps or curbs

Riding down low curbs can be done moving forwards. Make sure that the foot rests do not touch the ground.



A practiced user can negotiate small steps or curbs by himself:

- ⚠ **WARNING: Risk of tipping over – If you do not have enough experience with your wheelchair, ask assistance of an attendant.**
1. Bring balance on the rear wheels to reduce the pressure on the front wheels.
 2. Negotiate the curbs.

Higher curbs can be taken forward with an attendant:

1. Ask the attendant to tip the wheelchair slightly backwards.
2. Get past the curbs while moving on the rear wheels.
3. Put the wheelchair back on the four wheels.



An experienced user can negotiate higher curbs by himself. This is best done backwards.

1. Turn the wheelchair to have the rear wheels facing the curb.
2. Lean forward to move your centre of gravity forward.
3. Move the wheelchair close to the curbs.
4. Use the hand rim to roll-off wheelchair from the curb in a controlled manner.

2.12.2 Moving up steps or curbs

Moving up steps or curbs with attendant as follows:



1. Prevent the foot rests from touching the curb.
2. Ask the attendant to tip the wheelchair backwards, just enough to move the front wheels over the curb.
3. Lean backwards to move your centre of gravity above the rear wheel.
4. Place the front wheels on the curb.
5. Roll rear wheels of the wheelchair over the curb.

Higher curbs are negotiated backwards:

1. Turn the wheelchair to have the rear wheels facing the curb.
2. Lean backwards and move your centre of gravity above the rear wheels.
3. Ask the attendant to pull the wheelchair on the curb.
4. Take back the normal position in the wheelchair.

An experienced user can negotiate curbs by himself:

⚠ WARNING: Risk of tipping over – If you have not enough experience to control the wheelchair, get help from an attendant.



1. Drive until the curbs.
2. Ensure that the footrest don't touch the curbs.
3. Lean backwards so you are balancing on the rear wheels.



4. Role the front wheels balancing over the curbs.
5. Bend forwards for more stability.
6. Role the rear wheels over the curbs.

2.12.3 Taking of stairs

Taking of stairs while you staying in the wheelchair shall be according following rules:

⚠ WARNING: Risk of tipping over – Taking of stairs shall always with 2 attendants.

1. Remove the footrests.
2. One attendant tip the wheelchair slightly backwards.
3. The second attendant take the front of the frame.
4. Stay calm, avoid sudden movements and keep your arms inside the wheelchair.
5. Take the steps on the rear wheels of the wheelchair.
6. Mounting the footrests back after taking the stair.

2.13 Fold up the wheelchair

⚠ CAUTION: Chance of pinching – Do not place fingers between the components of the wheelchair.

1. Fold or remove the footplates (see § 2.5).
2. Swing the push bar away from the right hand-grip (standing behind the wheelchair).
3. Take the seat on the front side and backside and pull it up.

2.14 Taking off the wheels

To facilitate the transport off the wheelchair the rear wheels can be taken off:

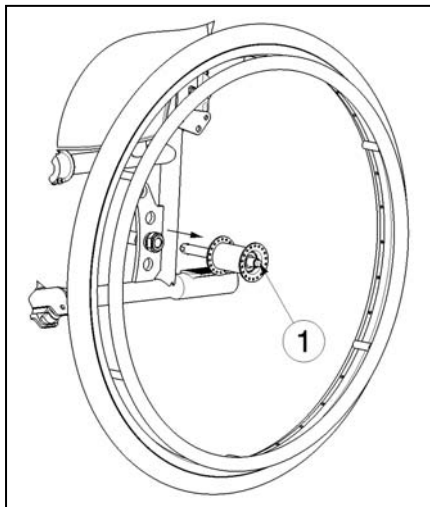

1. Make sure the brakes standing in the off position.
2. Take the wheelchair to the side frame where you want to remove the wheel.
3. Press the button ① in the center of the wheel hub.
4. Pull the wheel away from the frame.

2.15 Transport in the car

⚠ DANGER: Risk of injury – The wheelchair is not suited for use as a seat in a motor vehicle.

⚠ WARNING: Risk of injury – See that the wheelchair is attached properly. So you can avoid injury from the passengers during collision or sudden braking.

⚠ WARNING: Risk of injury – Use for attaching the wheelchair and passenger NEVER the same seatbelt.

Never use your wheelchair as a seat in an automobile or other vehicle. The wheelchair shall be marked with following symbol.



To transport the wheelchair in the car use following steps:

1. Remove footrests and accessories.
2. Store footrests and accessories safely.
3. If possible, fold the wheelchair and remove the wheels.
4. Place the wheelchair in the luggage place.
5. If the wheelchair and the passenger compartment is NOT separated, attach the frame of the wheelchair securely to the vehicle. You can use the available safety belts in the vehicle.

3 Installation and adjustment

The instructions in this chapter are for the specialist dealer.

The Vermeiren V100 XL has been designed to be adjust with a minimum of replacements parts. There is no need for extra stock of spare parts.

To find a service facility or specialist dealer near you, contact the nearest Vermeiren facility. A list of Vermeiren facilities can be found on the last page.

⚠ WARNING: Risk of unsafe settings - Use only the settings described in this manual.

⚠ WARNING: Variation of allowed adjustments can still change the stability of your wheelchair (tilt back or sideways).

3.1 Tools

To set up the wheelchair the following tools are needed.

- Wrench set n° 7 to n° 22
- Allen key set n° 3 to n° 8
- Screwdriver n° 4 to n° 5
- Screwdriver Phillips head

3.2 Manner of delivery

The Vermeiren V100 XL shall be delivered with:

- 1 frame with arm supports, rear and front wheels (seat height of 500 mm)
- 1 pair footrests
- Tools
- Manual
- Accessories

3.3 Adjusting the seat height

The Vermeiren V100 XL is adjustable in 3 seat heights by changing the wheels position. At each height there is a different setting of the front and rear wheels.

⚠ WARNING: The top hole of the axle plate is not intended for mounting the rear axle - This hole is for mounting the drum brake.

Seat height	Rear wheel	Front wheel
470 mm	Hole 1	Both bushings above the castor stem housing
500 mm (Standard)	Hole 2	One bushings above, and one under the castor stem housing
530 mm	Hole 3	Both bushings under the castor stem housing

Table 2: Seat heights

Change the seat height according the following steps:

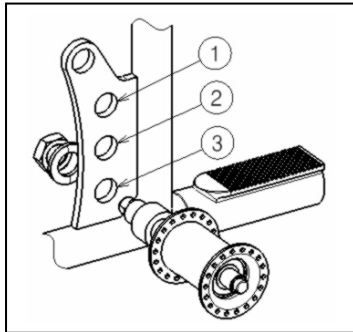

1. Remove the rear wheels (see § 2.14).
2. Screw the axle bushings of the rear wheels from the axle plate.
3. Assemble the axle bushings in the right hole of the axle plate, see Table 2.
4. Check if the axle bushings are fastened well.

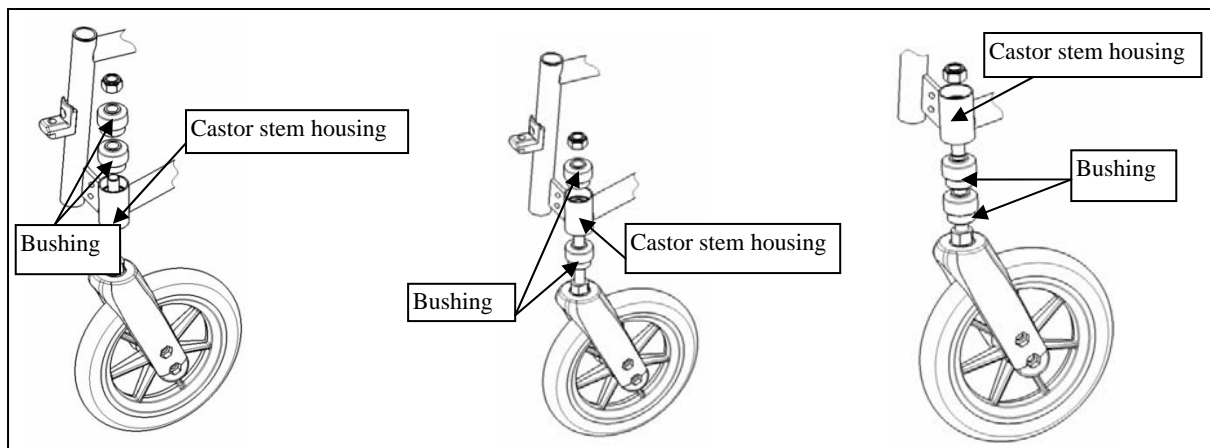

5. Screw the swivel axles of the front wheels loose.
6. Place the bushings according table 2.
7. Install the swivel axles of the front wheels and tighten them. Check the tension in the swivel axle so it turn smoothly, but there is no space for motion.
8. Mount the rear wheels.
9. If installed properly the swivel axles of the front wheels and the ground must be perpendicular. Check this.
10. Adjust the brakes according § 3.4.

3.4 Adjust the brakes

⚠ WARNING: Risk of injury – Brakes may only be adjusted by your specialist dealer.

Adjust the brakes according following rules:

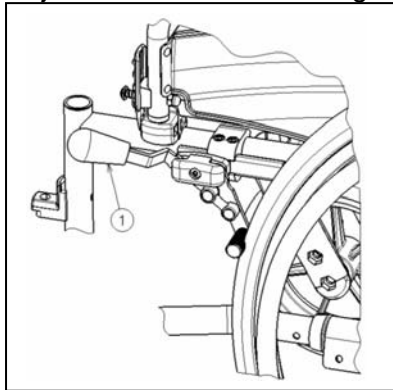

1. Install the wheels according § 2.2.
2. Disconnect the brakes by pulling lever ① backwards.

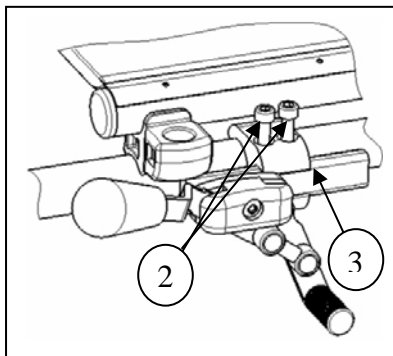

3. Loosen the bolts ② so the brake mechanism can slide over the guide ③.
4. Pull the brake mechanism over the guide ③ to the desired position.
5. Retighten the bolts ②.
6. Check working of the brakes.
7. If necessary repeat the above steps until the brakes are adjusted well.

3.5 Adjusting of the footrest

3.5.1 Length of the footrest

⚠ CAUTION: Risk of damage – Avoid that the footrest make any contact with the ground. Keep a minimum distance from 60 mm above the ground.

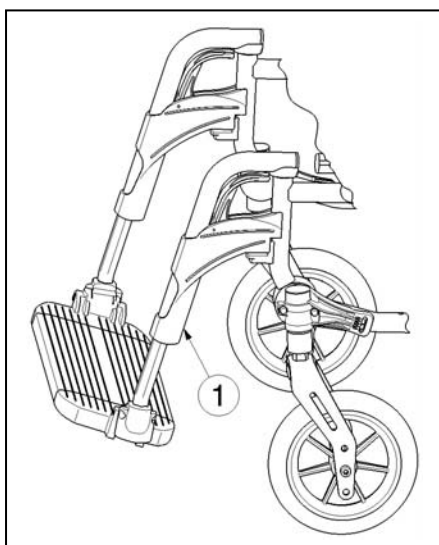

Adjust the length of the footrest as follow:

1. Remove the screw ① (on the back of the footrest).
2. Adjust the length of the footrest to a comfortable length.
3. Tighten the screw ① properly.

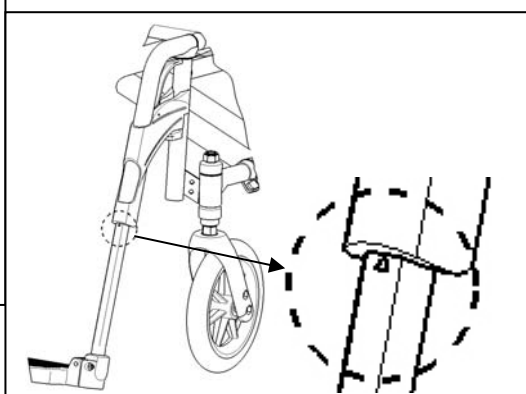

The max adjustable length of the footrest shall be marked with a triangle on the tube.

3.6 Adjusting the arm support

The arm support of your wheelchair can be adjustable in height and depth. The height of the arm support can be adjusted in 3 positions.

Height armsupport to seat	Number of the blocks under the tube	Number of blocks between tube and armrests
220 mm (Standard)	2	1
230 mm	1	2
240 mm	0	3

Table 3: Height of arm support

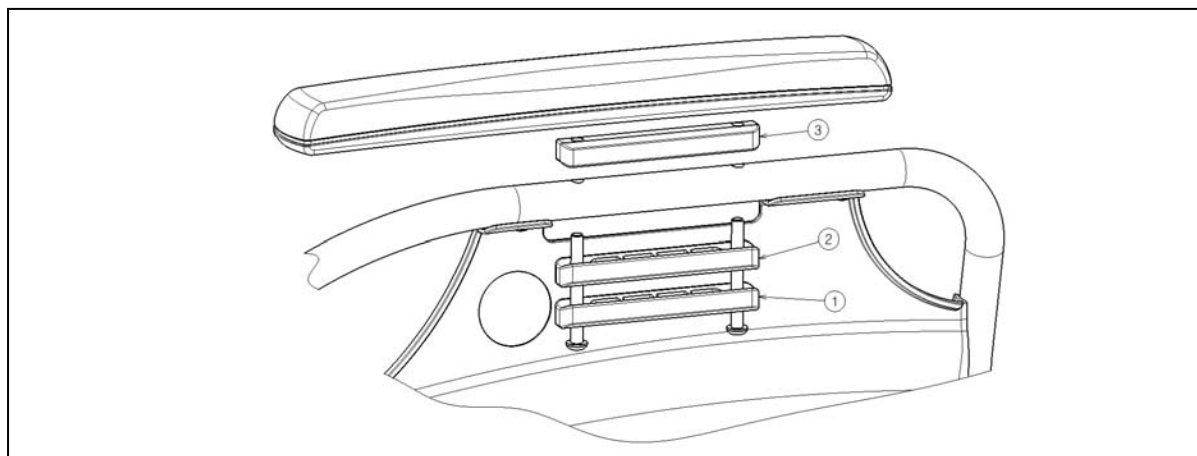

The depth of the armrest can be adjusted in 3 positions.

Depth of the armrest	Used holes
Front position	Back and middle
Middle position (Standard)	Hole 2 and 4
Back position	Front and middle

Table 4: Depth of armrest

Adjust the height and the depth of the armrest as follow:

1. Remove both screws under the armrest.
2. Place the correct number of blocks under and above the tubes, see table 4.
3. Install the armrest with the required holes for depth adjustment.

4 Maintenance

The expected lifetime of this wheelchair amounts 8 years. Lifetime of the wheelchair is influenced by its use, storage, regular maintenance, servicing and cleaning.

4.1 Regular Maintenance

The maintenance activities to ensure a good condition for your Vermeiren wheelchair are described below:

- Before every ride
 - Check the tyres and make them clean. If necessary change the tire.
 - Check screw fastenings are secured.
 - Check the brakes and adjusted if necessary.
 - Check the wheelchair (cleanliness, cracks, damage on structural parts ...) and make it clean. If necessary change the coating.
- Every 8 weeks: inspected and lubricating or adjusting from
 - Arm supports

- Footrests
- Brake lever
- Wheel axles
- Every 6 months or for every new user
 - General review
 - Disinfection
 - Frontwheels, possibly clean bearings

For your convenience, on the back of this manual is a maintenance plan.

Repairing and assembling of spare parts for your wheelchair may only be performed by the specialist dealer.

Only authorized Vermeiren spare parts may be installed.

4.2 Shipping and storage

The shipping and storage of the wheelchair shall be according following instructions:

- Store in a dry place (between +5 °C and +41 °C).
- The relative humidity of the air should be between 30% and 70%.
- Provide sufficient covering or packaging to protect the wheelchair from rust and foreign bodies. (e.g. salt water, sea air, sand, dust).
- Store all removed parts together in one place (or mark them if necessary) to avoid mixing up with other products when re-assembling.
- Components must be stored without being subjected to strains (Do not put too heavy parts on the wheelchair, not clamping between something, ...).

4.3 Care

4.3.1 Seat and back cushions

The cleaning of the seat and back cushions shall be according:

- Clean seat and back cushions with a cloth moistened with hot water. Be aware that you do not soak the seat and back cushions.
- Use a mild commercial detergent for removing stubborn dirt.
- Stains can be removed by using a sponge or a soft brush.
- Do not use strong cleaning liquids like solvents, nor use hard brushes.
- Never clean with steam and/or pressure washers.

4.3.2 Plastic parts

Clean plastic parts of your wheelchair with commercial plastic cleaners. Only use a soft brush or soft sponge.

Examples of plastic parts are the armrests, footrests, handles, tyres and

4.3.3 Coating

The high quality of the surface layer guarantees optimal protection against corrosion. If the outer coat is damaged by scratching or in some other way, get your specialist dealer to repair the affected surface.

When cleaning, only use warm water and normal household detergents and soft brushes and cloths. Ensure that no wetness gets into the tubes.

Initially the zinc parts only require rubbing with a dry cloth. Stubborn dirt can best be removed by using a suitable commercial zinc polish.

4.4 Inspection

In principle we recommend one inspection every year, and a minimum of one before usage is resumed. All of the following checks must be performed and documented by authorized persons:

- Check the frame parts and the hinged tubes for plastic deformation, cracks and impaired functioning.
- Visually check for damage to the paintwork (danger of corrosion)
- Check the operation of the wheels (free running, level rolling, axle play, tyres, profile, condition of the rims, air pressure in the case of air tyres, floating axles, etc.)
- Check the solidity and seating of all screws.
- Verify the amount of grease on the metal joints of movable parts
- The condition and security of the guides and axles of the steering wheels
- Visually check all plastic parts for cracks and brittle spots
- Check the functioning of the armrests and leg supports (locking, load, deformation, wear caused by loads).
- Check the operation of other detachable parts (example: anti-tipping device, personal safety belt, fitting back/seat, etc.)
- Completeness of the delivery condition, instruction manual available?

The service must only be signed off in the maintenance plan if a minimum of all the above-mentioned aspects have been checked.

4.5 Disinfection

- ⚠ WARNING: Dangerous Products - The use of disinfectants is restricted to authorized personnel.**
- ⚠ WARNING: Dangerous Products, change on irritate your skin - You should wear suitable protective clothing because the disinfectants could irritate your skin. For this purpose you should also take note of the product information of the solutions concerned.**

All parts of the wheelchair can be treated by scrubbing with a disinfectant.

All steps taken to disinfect rehabilitation equipment, their components or other accessory parts are to be recorded in a disinfection report containing a minimum of the following information (with product documentation appended):

Date of the disinfection	Reason	Specification	Substance and concentration	Signature
--------------------------	--------	---------------	-----------------------------	-----------

Table 5: Example of a disinfection book

Abbreviations used in column 2 (reason):

V = Suspected infection IF = Infection case W = Repetition I = Inspection

For a blank sheet of a disinfection book see § 9.

The recommended disinfectants for scrubbing (based on the list provided by the Robert Koch Institute, RKI) are standing in the table below. The current state of the disinfectants included in the RKI list can be obtained from the Robert Koch Institute (RKI) (homepage: www.rki.de).

Active substance	Product name	Laundry disinfection		Surface disinfection (scrubbing-/wiping disinfection)		Disinfection of excretions 1 part sputum or stools + 2 parts diluted solution or 1 part urine + 1 part diluted solution						Area of effectiveness	Manufacturer or Supplier
		Diluted solution	Time to take effect	Diluted solution	Time to take effect	Sputum		Stools		Urine			
						%	Hr.	%	Hr.	%	Hr.		
Phenol or phenol derivative	Amocid	1	12	5	6	5	4	5	6	5	2	A	Lysoform
	Gevisol	0,5	12	5	4	5	4	5	6	5	2	A	Schülke & Mayr
	Helipur			6	4	6	4	6	6	6	2	A	B. Braun
	m-cresylic soap solution (DAB 6)	1	12	5	4							A	
	Phenol	1	12	3	2							A	
Chlorine, organic or inorganic substances with active chlorine	Chloramin-T DAB 9	1,5	12	2,5	2	5	4					A ¹ B	
	Clorina	1,5	12	2,5	2	5	4					A ¹ B	Lysoform
	Trichlorol	2	12	3	2	6	4					A ¹ B	Lysoform
Per combinations	Apesin AP100 ²			4	4							AB	Tana PROFESSIONAL
	Dismozon pur ²			4	1							AB	Bode Chemie
	Perform ²			3	4							AB	Schülke & Mayr
	Wofesterii ²			2	4							AB	Kesla Pharma
Formaldehyde and/or other aldehydes or derivatives	Aldasan 2000			4	4							AB	Lysoform
	Antifect FD 10			3	4							AB	Schülke & Mayr
	Antiseptica surface disinfection 7			3	6							AB	Antiseptica
	Apesin AP30			5	4							A	Tana PROFESSIONAL
	Bacillocid special			6	4							AB	Bode Chemie
	Buraton 10F			3	4							AB	Schülke & Mayr
	Desomed A 2000			3	6							AB	Desomed
	Hospital disinfectant cleaner			8	6							AB	Dreiturm
	Desomed Perfekt			7	4							AB*	Desomed
	Formaldehyde-solution (DAB 10), (formaline)	1,5	12	3	4							AB	
	Incidin Perfekt	1	12	3	4							AB	Ecolab
	Incidin Plus			8	6							A	Ecolab
	Kohrsolin	2	12	3	4							AB	Bode Chemie
	Lysoform	4	12	5	6							AB	Lysoform
	Lysoformin	3	12	5	6							AB	Lysoform
	Lysoformin 2000			4	6							AB	Lysoform
	Melsept	2	12	4	6							AB	B. Braun
	Melsitt	4	12	10	4							AB	B. Braun
	Minutil	2	12	6	4							AB	Ecolab
	Multidor			3	6							AB	Ecolab
Nüscosept			5	4							AB	Dr. Nüsken Chemie	
Optisept			7	4							AB*	Dr. Schumacher	
Pursept-FD			7	4							AB*	Merz	
Ultrasol F	3	12	5	4							AB	Fresenius Kabi	
Amphoteric surfactants (amfotensiden)	Tensodur 103	2	12									A	MFH Marienfelde
Lye	Lime-milk ³							20	6			A ³ B	

1 Not effective against myco-bacteria when service disinfecting, especially in the presence of blood.

2 Not suitable for disinfecting blood-contaminated or porous surfaces (e.g. raw wood).

3 Useless for tuberculosis; preparation of Lime-milk: 1 part dissolved lime (calcium hydroxide) + 3 parts water.

* Checked for effectiveness on viruses in accordance with checking methods of the RKI (Federal Health Reporting 38 (1995) 242).

A: Suitable for killing vegetative bacterial germs including myco-bacteria as well as fungi, including fungal spores.

B: Suitable for deactivating viruses.

Table 6: Disinfectants

Kindly consult your specialist dealer if you have queries on matters related to disinfection; he will gladly assist you.

5 Guarantee

Excerpt from the "General Business Conditions":

(...)

5. The guarantee period for warranty claims is 24 months. As a result of our superior quality requirements, we can increase the time bar on warranty claims beyond these fundamental, statutory requirements for

(...)

-Frame and cross-hinge of wheelchairs

4 years

The guarantee excludes damage arising from structural changes to our products, insufficient maintenance, defective or improper handling or storage or the use of non-original parts. Likewise, the guarantee excludes parts or working parts subject to natural wear and tear.

(...)

6 Disposal

When disposing of the wheelchair, contact your local disposal centre or return the product to your specialist dealer who, after submitting it to a hygienic procedure, will be able to send it back to the manufacturer who will dispose of and recycle it correctly, separating it into its component materials.

Packaging materials can be taken to disposal or recycling centers or to your specialist dealer.

7 Declaration of conformity

The manufacturer or his authorized representative :

N.V. VERMEIREN N.V

Address :

Vermeirenplein 1/15

2920 Kalmthout

Belgium

declares under his sole responsibility that the CE marked medical devices :

Productgroup: Manual wheelchairs

Brand: Vermeiren

Type: V100 XL

have been classified as class I, according to annex IX MDD 93/42/EEC, rule 1,

and is manufactured in full conformity with the European instructions below - including the latest modifications - and with the national law, that organizes this directions :

Medical devices directive MDD 93/42/EEC

and is in conformity with the relevant European harmonized standards:

EN 12182: 1999, EN 12183: 2009



8 Maintenance plan

Date	Maintenance	Remarks	Paraph
1/1/2012	<i>Greasing and general servicing</i>	<i>non</i>	

9 Disinfection book

Date of the disinfection	Reason	Specification	Substance and concentration	Signature

Abbreviations used in column 2 (reason):
V = Suspected infection IF = Infection case W = Repetition I = Inspection



SERVICE

The manual wheelchair was serviced:

Dealer's stamp:

Date:

Dealer's stamp:

Date:

Dealer's stamp:

Date:

Dealer's stamp:

Date:

Dealer's stamp:

Date:

Dealer's stamp:

Date:

Dealer's stamp:

Date:

Dealer's stamp:

Date:

Dealer's stamp:

Date:

Dealer's stamp:

Date:

- For service checklists an additional technical information, please see our specialist dealers nearest to you. More information on our website at: www.vermeiren.com.



Notes

A series of horizontal dotted lines for writing notes.

Belgium

N.V. Vermeiren N.V.

Vermeirenplein 1 / 15
B-2920 Kalmthout
Tel: +32(0)3 620 20 20
Fax: +32(0)3 666 48 94
website: www.vermeiren.be
e-mail: info@vermeiren.be

France

Vermeiren France S.A.

Z. I., 5, Rue d'Ennevelin
F-59710 Avelin
Tel: +33(0)3 28 55 07 98
Fax: +33(0)3 20 90 28 89
website: www.vermeiren.fr
e-mail: info@vermeiren.fr

Italy

Reatime S.R.L.

Viale delle Industrie 5
I-20020 Arese MI
Tel: +39 02 99 77 07
Fax: +39 02 93 58 56 17
website: www.reatime.it
e-mail: info@reatime.it

Poland

Vermeiren Polska Sp. z o.o

ul. Łączna 1
PL-55-100 Trzebnica
Tel: +48(0)71 387 42 00
Fax: +48(0)71 387 05 74
website: www.vermeiren.pl
e-mail: info@vermeiren.pl

Czech Republic

Vermeiren ČR S.R.O.

Nadrazni 132
702 00 Ostrava 1
Tel: +420 596 133 923
Fax: +420 596 133 277
website: www.vermeiren.cz
e-mail: info@vermeiren.cz

Germany

Vermeiren Deutschland GmbH

Wahlerstraße 12 a
D-40472 Düsseldorf
Tel: +49(0)211 94 27 90
Fax: +49(0)211 65 36 00
website: www.vermeiren.de
e-mail: info@vermeiren.de

Austria

L. Vermeiren Ges. mbH

Winetzhammerstraße 10
A-4030 Linz
Tel: +43(0)732 37 13 66
Fax: +43(0)732 37 13 69
website: www.vermeiren.at
e-mail: info@vermeiren.at

Switzerland

Vermeiren Suisse S.A.

Hühnerhubelstraße 59
CH-3123 Belp
Tel: +41(0)31 818 40 95
Fax: +41(0)31 818 40 98
website: www.vermeiren.ch
e-mail: info@vermeiren.ch

Spain / Portugal

Vermeiren Iberica, S.L.

Carretera de Cartellà, Km 0,5
Sant Gregori Parc Industrial, Edifici A
17150 Sant Gregori (Girona)
Tel: +34 902 48 72 72
Fax: +34 972 40 50 54
website: www.vermeiren.es
e-mail: info@vermeiren.es